



Repair Manual and Spare Parts List

**ZF 63 IV
ZF 80 IV
ZF 80-1 IV
ZF 85 IV**

FEBRUARY 2006
cod. **310.01.0009h**



TABLE OF CONTENTS

INTRODUCTION	3	4.3 OUTPUT SHAFT	20
1. MAJOR COMPONENTS	5	4.3.1 Preparations for assembly.....	20
1.1 MAJOR TRANSMISSIONS COMPONENTS.....	5	4.3.2 Mounting inner race of tapered roller bearing.....	20
1.2 CLEANERS AND SEALANTS.....	6	4.3.3 Pressing the gear on.....	20
1.3. MEASURING TOOLS.....	6	4.4 PREASSEMBLY OF HOUSING	21
1.4. STANDARD TOOLS AND FIXTURE.....	6	4.4.1 Assembly of outer races (tapered roller bearings).....	21
2. SPECIAL TOOLS	7	4.4.2 Installation of fluid suction pipe.....	21
3. DISASSEMBLY	9	4.4.3 Assembling input shaft seal.....	22
INTRODUCTION.....	9	4.4.4 Mounting the breather filter.....	22
3.1. FLUID FILTER.....	9	4.5 MEASURING THE BEARING CLEARANCE/ ADJUSTING THE PRETENSION OF BEARINGS .	23
3.1.1 Remove fluid filter.....	9	4.5.1 General.....	23
3.1.2 Suction of transmission fluid.....	9	4.5.2 Mounting outer races of tapered roller bearings into housing.....	23
3.1.3 Suction of transmission fluid on ZF 63 IV, ZF 80 IV, ZF 80-1 IV and ZF 85 IV.....	9	4.5.3 Inserting gear set into housing.....	23
3.2 REMOVAL DIPSTICK.....	10	4.5.4 Measuring bearing clearance on input shaft.....	24
3.3 REMOVAL BREATHER VALVE.....	10	4.5.5 Measuring bearing clearance at intermediate and reversal shafts.....	24
3.4 OUTPUT FLANGE.....	10	4.5.6 Measuring the bearing clearance on the output shaft.....	25
3.5 REMOVAL CONTROL BLOCK.....	11	4.5.7 Adjusting the pretension clearance of bearings.....	25
3.5.1 Neutral Safety Switch.....	11	4.5.8 Final assembly of the housing.....	26
3.5.2 Neutral Safety Switch Check.....	11	4.6 CONTROL BLOCK	27
3.6 HOUSING.....	12	4.6.1 Mounting the control block.....	27
3.6.1 Disassemble the transmission housing halves.....	12	4.7 FLUID FILTER	27
3.6.2 Removal of shafts and gears.....	12	4.7.1 Mounting the fluid filter.....	27
3.6.3 Removal of radial shaft seals.....	12	4.8 MAKING THE TRANSMISSION READY FOR OPERATION	27
3.6.4 Removal of fluid inlet pipe.....	13	4.8.1 Filling up with Transmission Fluid.....	27
3.7 TAPERED ROLLER BEARINGS.....	14	4.8.2 Inserting fluid filter into housing.....	27
3.7.1 Disassembling the outer races of taper roller bearing.....	14	4.8.3 Check fluid level.....	28
3.7.2 Removal of inner races of taper roller bearings.....	14	5. ADJUSTMENT DATA	29
3.8 REVERSING CLUTCH PACK.....	15	5.1 SHIFTING PRESSURE.....	29
3.8.1 Removal of the clutch discs.....	15	5.1.1 ZF 80-1 IV VERSION - ZF 85 IV.....	29
4. ASSEMBLY	17	5.1.2 ZF 63 IV - ZF 80 IV VERSION.....	29
INTRODUCTION.....	17	5.1.3 ZF 63 IV INDMAR VERSION.....	30
4.1 INPUT SHAFT.....	17	5.2 LUBE OIL DELIVERY RATE.....	30
4.1.1 Mount discs into reversing clutch.....	17	5.2.1 ZF 80-1 IV VERSION - ZF 85 IV.....	30
4.1.2 Install needle bearings and gear.....	18	5.2.2 ZF 63 IV - ZF 80 IV VERSION.....	31
4.1.3 Assemble butting rings.....	18	5.2.3 ZF 63 IV INDMAR VERSION.....	31
4.1.4 Mounting inner races of tapered roller bearings.....	19	6. HYDRAULIC DIAGRAM	32
4.1.5 Assemble piston rings.....	19	7. TIGHTENING TORQUES	33
4.2 INTERMEDIATE AND REVERSAL SHAFT.....	20	8. FUNCTION TEST	34
4.2.1 Mounting inner races of tapered roller bearings.....	20		



9. TROUBLESHOOTING	35	13. SPARE PARTS LIST ZF 85 IV	85
10. AUTOMATIC TRANSMISSION FLUID	40	Preface	85
11. SPARE PARTS LIST ZF63 IV - ZF80 IV - ZF80-1 IV .	43	Name plate.....	85
Preface	43	FIG. 1 ZF 85 IV	86
Name plate.....	43	FIG. 2 ZF 85 IV	88
FIG. 1 ZF 63 IV.....	44	FIG. 3 Mechanical selector valve ZF 85 IV	90
FIG. 1 ZF 80 IV - ZF 80-1 IV	46	FIG. 4 Electric selector valve ON/OFF 12V - 26 bar	
FIG. 2 ZF 63 IV.....	48	Electric selector valve ON/OFF 24V - 26 bar	
FIG. 2 ZF 80 IV - ZF 80-1 IV	50	ZF 85 IV	92
FIG. 3 Mechanical selector valve		FIG. 5 Electric selector valve ON/OFF 12V - 26 bar	
ZF 63 IV - ZF 80 IV - ZF 80-1 IV.....	54	with trolling valve	
FIG. 4 Old electric selector valve with		Electric selector valve ON/OFF 24V - 26 bar	
proportional valves		with trolling valve	
ZF 63 IV - ZF 80 IV - ZF 80-1 IV.....	56	ZF 85 IV	94
FIG. 5 ZF 63 IV - ZF 80 IV - ZF 80-1 IV.....	58	KIT COMPONENTS ZF 85 IV	96
FIG. 6 Old electric selector valve		14. SPARE PARTS LIST ZF 80 IV	
ON/OFF 12V, 26 BAR		(ZF 85 IV DERIVATE VERSION)	97
ZF 63 IV - ZF 80 IV - ZF 80-1 IV.....	60	Preface	97
FIG. 7 New electric selector valve ON/OFF 12V - 26 bar		Name plate.....	97
New electric selector valve ON/OFF 24V - 26 bar		FIG. 1 ZF 80 IV (ZF 85 IV DERIVATE VERSION)	98
ZF 63 IV - ZF 80 IV - ZF 80-1 IV.....	62	FIG. 2 ZF 80 IV (ZF 85 IV DERIVATE VERSION)	100
FIG. 8 New electric selector valve on/off 12v - 26 bar		FIG. 3 Mechanical selector valve	
with trolling valve		ZF 80 IV (ZF 85 IV DERIVATE VERSION)	102
New electric selector valve on/off 24v - 26 bar		FIG. 4 Electric selector valve ON/OFF 12V - 26 bar	
with trolling valve		Electric selector valve ON/OFF 24V - 26 bar	
ZF 63 IV - ZF 80 IV - ZF 80-1 IV.....	64	ZF 80 IV (ZF 85 IV DERIVATE VERSION)	104
KIT COMPONENTS ZF 63 IV.....	66	FIG. 5 Electric selector valve ON/OFF 12V - 26 bar	
KIT COMPONENTS ZF 80 IV - ZF 80-1 IV	67	with trolling valve	
12. SPARE PARTS LIST		Electric selector valve ON/OFF 24V - 26 bar	
ZF 80 IV (029 - 030 - 031 - 032 - 033 VERSION)		with trolling valve	
ZF 80 - 1 IV (034 - 035 - 036 - 037 - 038 VERSION) ..	69	ZF 80 IV (ZF 85 IV DERIVATE VERSION)	106
Preface	69	KIT COMPONENTS ZF 80 IV	
Name plate.....	69	(ZF 85 IV DERIVATE VERSION)	108
FIG. 1 ZF 80 IV, ZF 80 - 1 IV.....	70		
FIG. 2 ZF 80 IV, ZF 80 - 1 IV.....	72		
FIG. 3 Mechanical selector valve			
ZF 80 IV, ZF 80 - 1 IV.....	76		
FIG. 4 Old electric selector valve			
ON/OFF 12V, 26 bar ZF 80 IV, ZF 80 - 1 IV ...	78		
FIG. 5 New electric selector valve ON/OFF 12V - 26 bar			
New electric selector valve ON/OFF 24V - 26 bar			
ZF 80 IV, ZF 80 - 1 IV.....	80		
FIG. 6 New electric selector valve on/off 12v - 26 bar			
with trolling valve			
New electric selector valve on/off 24v - 26 bar			
with trolling valve			
ZF 80 IV, ZF 80 - 1 IV.....	82		
KIT COMPONENTS			
ZF 80 IV, ZF 80 - 1 IV	84		



INTRODUCTION

This manual gives specific instructions for the proper repair on ZF 63 IV - ZF 80 IV - ZF 80-1 IV - ZF 85 IV model transmissions.

Please follow the procedures carefully to insure quality service.

ZF-HURTH MARINE recommends to read the manual completely before starting with repairs, as some of the procedures described are rather complex.

Along with standard tools, ZF-HURTH MARINE recommends the use of special tools, necessary to perform repairs correctly. The special tools are available through your local ZF-HURTH MARINE dealer.

This manual is based on the technical information at the time of printing. The manual has been checked carefully in order to avoid errors. However ZF-HURTH MARINE is not liable, for any misrepresentations, errors of description or omissions.

Modifications on future manuals may be introduced without prior notice.



1. MAJOR COMPONENTS

1.1 MAJOR TRANSMISSIONS COMPONENTS

The main components of the ZF Marine Transmissions are:

ITEM	DESCRIPTION
1	Two-piece aluminum die cast
1.1	Oil filter
1.2	Oil dipstick
1.3	Oil drain plug
1.4	Breather valve

ITEM	DESCRIPTION
2	Gears
2.1	Input shaft with reversing clutch pack assembly
2.2	Intermediate shafts
2.3	Reversal shaft
3	Control block

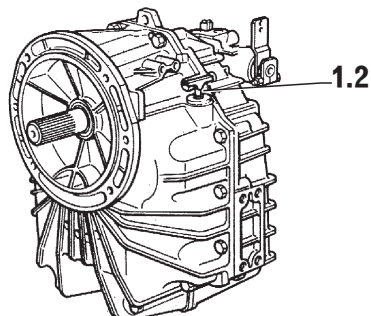
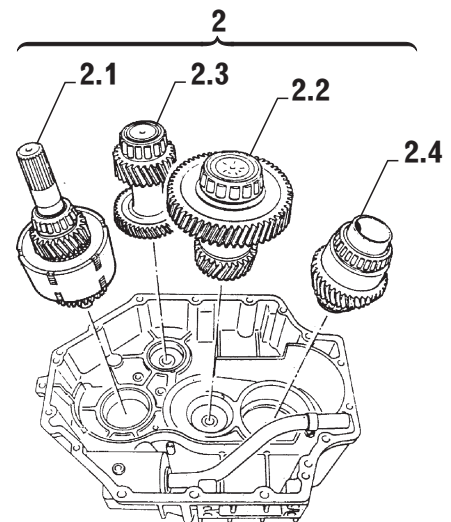
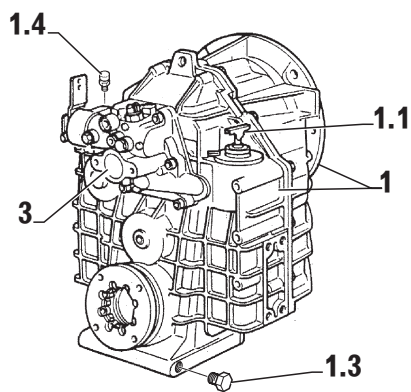

1.2 CLEANERS AND SEALANTS

For cleaning:

Cold cleaner such as benzine, trichloroethane or Loctite fast cleaner No. 7063.

⚠ WARNING

Keep detergents away from your skin, do not drink and do not inhale their vapors!

Always wear protective gloves and safety glasses!

Note accident prevention rules!

For assembly:

- Loctite 243 for securing screws, medium-hard

- Loctite 245 for securing output flange on spline
- Loctite 518 for housing surfaces.
- Loctite 574 for outer diameter sealing rings.
- Grease: Staburags NBU 30, Klüber Co. for radial shaft seals
- ATF Fluid:
 - 4.4 liters (1.1 US gallons) for ZF 63 IV
 - 7.0 liters (1.85 US gallons) for ZF 80 IV - ZF 80-1 IV.
 - 7.0 liters (1.85 US gallons) for ZF 85 IV.

1.3. MEASURING TOOLS

MICROMETER

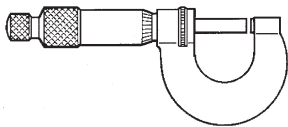

Measuring gauge from 0-25 mm (0-1.0 in.)
Accuracy of reading 1/100 mm (0.0004 in.)

DIAL INDICATOR GAUGE WITH ARM-TYPE SUPPORT

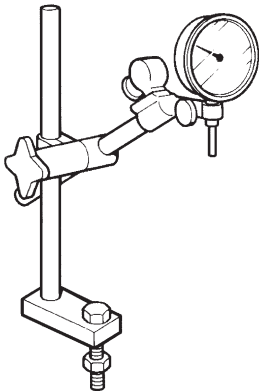

DIAL GAUGE INCREMENTS

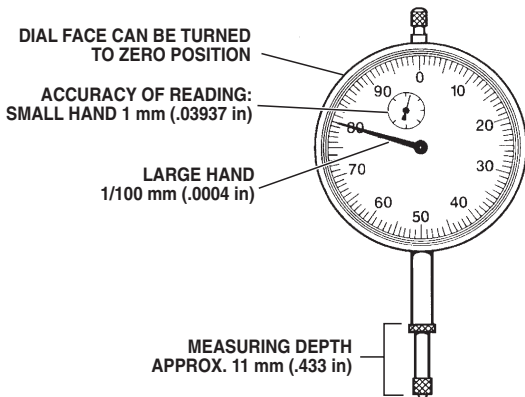

FEELER GAUGE

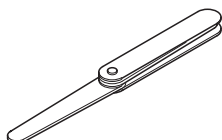

1.4. STANDARD TOOLS AND FIXTURE

WRENCH for hexagon bolts (8-17-19-22 mm) (7/8")



ALLEN WRENCH (6 mm)

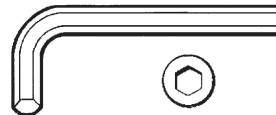

HEXAGON SOCKET WRENCH (6-8-17-19 mm)

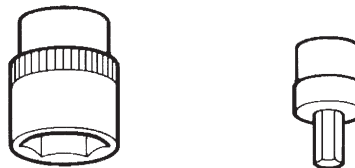

TORQUE WRENCH

adjustable up to 180 Nm (152 ft.lb.)



PLASTIC HAMMER (1000 g) and sturdy screwdriver

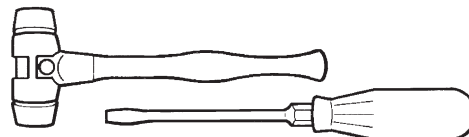

EXTRACTOR minimum diameter 130 m

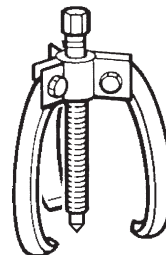

PLIER

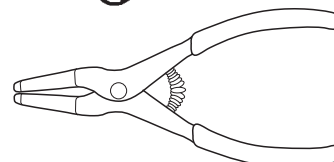



2. SPECIAL TOOLS

It is assumed that all standard tools, such as, torque wrenches, open-end wrenches, allen keys and extractors, are available.

All fixtures for pressing parts in or out should be used in conjunction with a hydraulic or manual press.

EXTRACTOR

Tapered roller bearing inner races

Basic Unit P/N 978.25.0017.0 (454421)

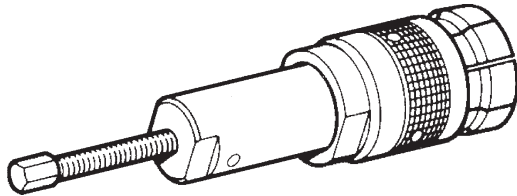

ADAPTER for basic unit 978.25.0017.0 (454421).

For bearing input shaft - spline side.

- P/N 978.25.0018.0 (469686) ZF 63 IV
- P/N 978.35.0019.0 (500465) ZF 80 IV - ZF 80-1 IV - ZF 85 IV

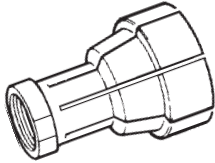

EXTRACTOR SPLIT RING

Input shaft.

Taper roller bearing inner race - control block side.

P/N 224.836.009 (456170)

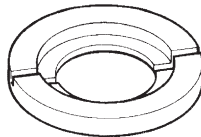

EXTRACTOR Tapered roller bearing outer races basic unit P/N 978.25.0021.0 (454422)

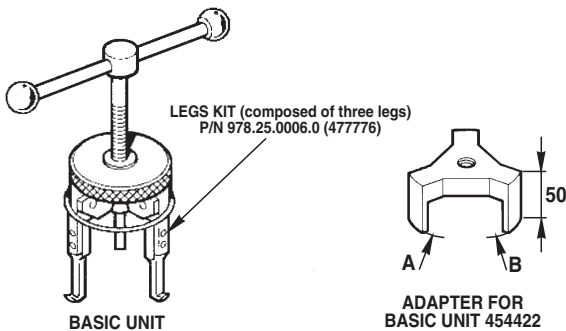

ZF 63 IV	ZF 80 IV - ZF 80-1 IV - ZF 85 IV
—	978.25.0009.0 (477853)
—	978.25.0011.0 (477854)
978.25.0013.0 (477857)	—
978.30.0014.0 (477858)	978.30.0014.0 (477858)
—	978.35.0016.0 (477895)

CLAMPING RING for measuring the bearing clearance input shaft P/N 219.354.3 (618582)

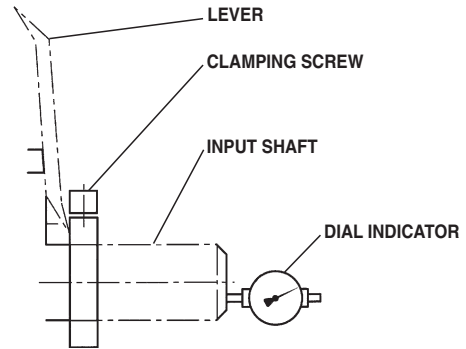

MANDREL

For disassembly and assembly

Shaft seal - input side : P/N 224.836.005 (454425)

Shaft seal output propeller side:

- P/N 978.30.0001.0 (500445) ZF 63 IV
- P/N 20.1040.01 ZF 80 IV - ZF 80-1 IV - ZF 85 IV

Output shaft seal control block side:

- P/N 978.30.0003.0 (500447) ZF 63 IV
- P/N 20.1040.02 ZF 80 IV - ZF 80-1 IV - ZF 85 IV

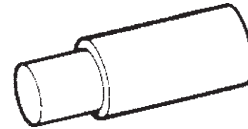

For assembling input shaft seal on the input spline side

Bushing P/N 20.0012.01 to insert input shaft seal

Only for models: ZF 63 IV - ZF 80 IV - ZF 80-1 IV

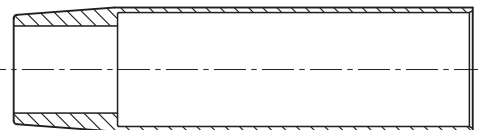

Mandrel P/N 20.0012.02 to assemble input shaft seal

Only for models: ZF 63 IV - ZF 80 IV - ZF 80-1 IV

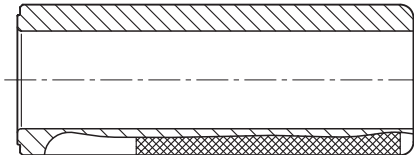

Mandrel P/N 20.1072.01 to assemble input shaft seal

Only for model: ZF 85 IV - ZF 80 IV (ZF 85 IV DERIVATE VERSION)

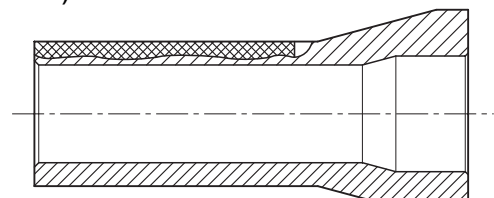

SHIM

To determinate the correct preload of the tapered roller bearings.

- P/N 20.1017.00 ZF 63 IV
- P/N 20.1019.00 ZF 80 IV - ZF 80-1 IV - ZF 85 IV

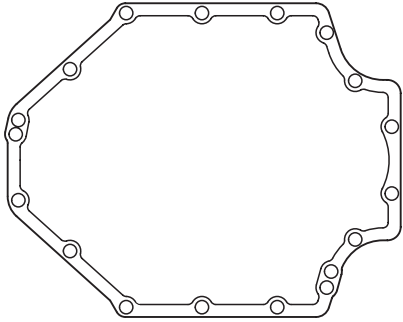
**SPECIAL HEX HEAD BOLT WITH BEARING**

for measuring the bearing clearance intermediate shaft
P/N. 224.836.008 (458105)

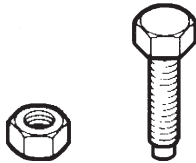
**PUNCH**

for assembly Seal - suction pipe

- ZF 80 IV - ZF 80-1 IV - ZF 85 IV P/N 20.1021.00
- ZF 63 IV: P/N 20.1029.00

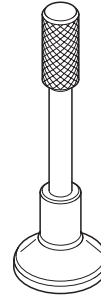

CENTRE SQUARE PUNCH To position the oil suction pipe into housing P/N 20.1041.00

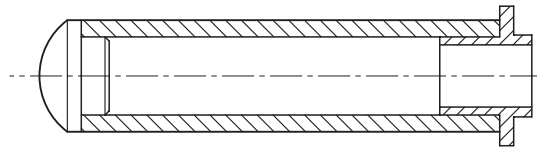



3. DISASSEMBLY

INTRODUCTION

Clean the transmission thoroughly on the outside before disassembly.

The repair area should be clean and well lighted. ZF HURTH MARINE recommends using a swiveling stand for aiding in assembly and disassembly.

**Swiveling stand ZF
Output - half side up**

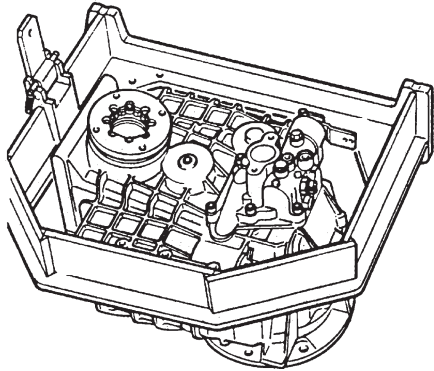

**Swiveling stand ZF
Input - half side up**

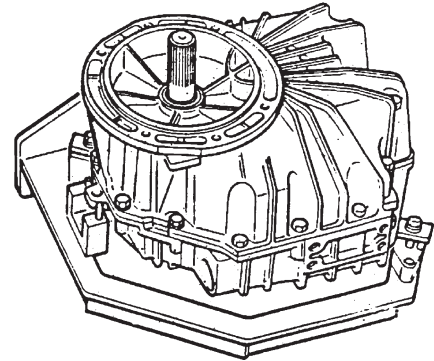

3.1 FLUID FILTER

3.1.1 Remove fluid filter

Turn the screw that fixes the oil filter cover in a counter-clockwise direction and remove the filter from its housing (item 1, fig. 1-1). Use a 6 mm Allen wrench.

Pull filter element off (item 2, fig.1-1).

Check O-rings (item 3 and 4, fig. 1-1) for wear, replace if necessary.

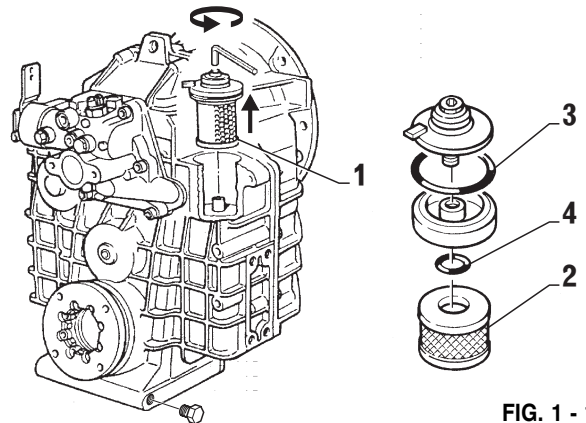

FIG. 1 - 1

3.1.2 Suction of transmission fluid

Push hose of suction pump (item 1, Fig. 1-2) through the suction pipe (item 2, Fig. 1-2) down to the bottom of the housing and suck the fluid off.

3.1.3 Suction of transmission fluid on ZF 63 IV, ZF 80 IV, ZF 80-1 IV and ZF 85 IV

Remove the plug (item 3, Fig. 1-2) and let the oil flow from the proper hole.

IMPORTANT

The used oil and the oil filter are to be handled as special waste that pollute the environment. For the safe disposal of used oil and filter, take all the measures required by the relevant local rules and legislation.

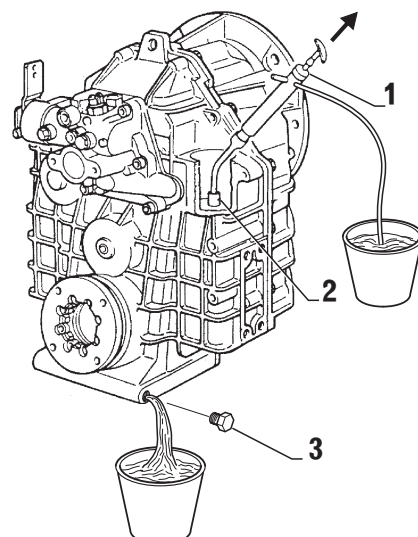

FIG. 1 - 2

3.2 REMOVAL DIPSTICK

Unscrew dipstick (item 1, Fig. 2-1) (counterclockwise) and pull out of housing.
Replace O-Ring if present (check parts list section 11).

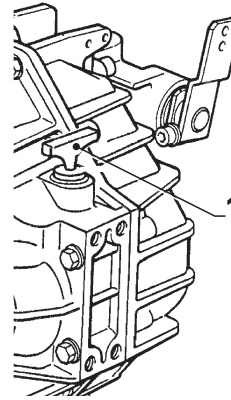

FIG. 2 - 1

3.3 REMOVAL BREATHER VALVE

Unscrew breather valve (item 1, Fig. 3-1). Wash valve in a detergent, let dry and dip in oil, then let oil drip off.

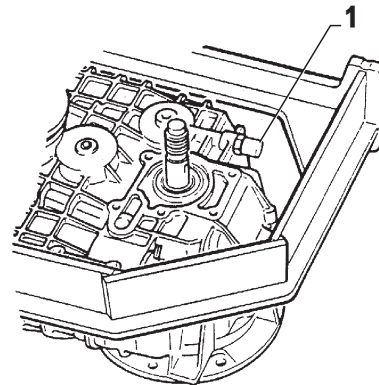

FIG. 3 - 1

3.4 OUTPUT FLANGE

Unscrew socket head bolts (item 1, Fig. 4-1) up to four opposite ones.

Apply forcing plate and position screw heads with regard to forcing plate boreholes by means of Allen key (item 1, Fig. 4-2). Using an Allen key, turn screws positioned in the output flange against forcing plate.

This will press the output flange off the output shaft (Fig. 4-2).

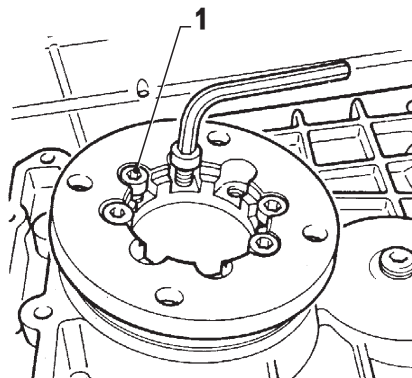

FIG. 4 - 1

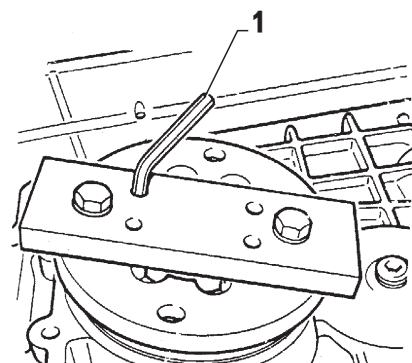

FIG. 4 - 2



3.5 REMOVAL CONTROL BLOCK

Unscrew allen head bolts (item 1, Fig. 5-1).
 Pull control block (item 2, Fig. 5-1) together with seal (item 3, Fig. 5-1) off the input shaft.
 Remove key (item 4, Fig. 5-1) from input shaft (item 5, Fig. 5-1).

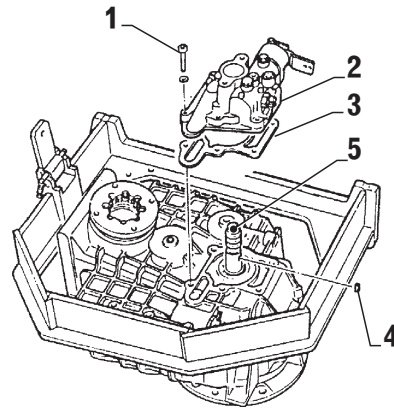

FIG. 5 - 1

3.5.1 Neutral Safety Switch

Unscrew neutral safety switch (item 1, Fig. 5-2).
 Note: Use 7/8 inch wrench for hex bolts.
 To reassemble neutral safety switch:
 tightening torque: 25 Nm (18.5 ft.lb.)

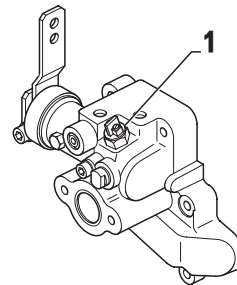

FIG. 5 - 2

3.5.2 Neutral Safety Switch Check

To check for proper operation of the switch perform one of the following tests:

A: Ohm meter

Connect the ohm meter leads to the terminal connection of the switch.

With the pin (item 1a Fig. 5-3) extended you should get a reading, indicating a good switch.

Compressing the pin (item 1b Fig. 5-3) you should have "O" reading,

B: 12 volt light

Connect the neutral safety switch with a light in series to a 12 volt battery. The switch is good when the light goes out when the center pin (item 1b Fig. 5-3) is compressed.

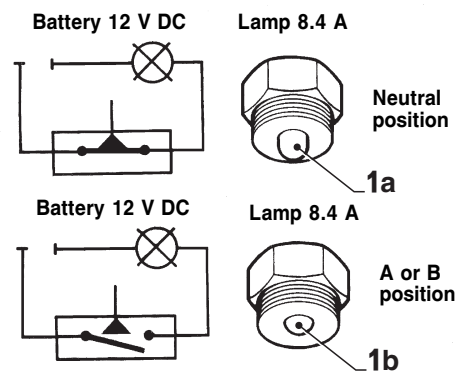

FIG. 5 - 3

3.6 HOUSING

3.6.1 Disassemble the transmission housing halves

Using a adequate drift punch, top the locating pins (item 1, Fig. 6-1a and 6-1b) out of the housing.

Loosen and remove all hex head bolts and lock washers (item 2 and 3, Fig. 6-1b). Using a plastic hammer slightly top the split line of the case halves to break the seal. Then remove the input side of the housing.



IMPORTANT

Only transmission type ZF 63 IV, $i=2.0$ and $i=2.5$. First remove radial shaft seal ring (item 4, Fig. 6-1b) to remove the housing half.

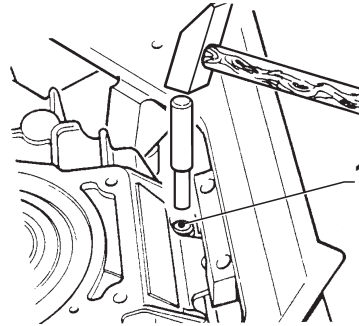

FIG. 6 - 1a

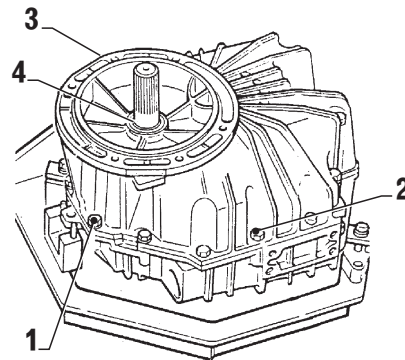

FIG. 6 - 1b

3.6.2 Removal of shafts and gears

Take the gear set out of the housing

- intermediate shaft (item 1, Fig. 6-2)
- input shaft (item 2, Fig. 6-2)
- output shaft (item 4, Fig. 6-2)
- reversal shaft (item 3 Fig. 6-2).

Check all gears, bearings and three piston rings on the input shaft (item 2, Fig. 6-2) for signs of wear or failure. If any of the gears are damaged or showing signs of excessive wear ZF-HURTH MARINE recommends replacing the complete gear set.

When taper roller bearings need replacing on the input shaft, the butting rings and needle bearings should also be replaced. When replacing inner roller bearings use the same manufacturer.

To check for correct clutch operation, rotate the gears on the input shaft. If it is hard to turn the gears, the clutch is probably damaged.

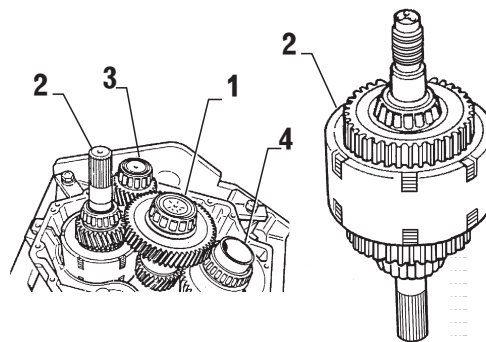

FIG. 6 - 2

3.6.3 Removal of radial shaft seals

Input shaft seal

Using a seal mandrel inside the housing top the input shaft seal out. Discard seal and replace with a new seal. (item 2, Fig. 6-3a).

NOTE

For transmission types ZF63 IV, $i=2.0$ and $i=2.5$ (item 2, Fig. 6-3a) the radial shaft seal ring has already been removed before dismounting the housing half.

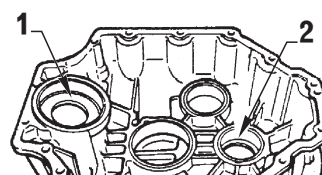

FIG. 6 - 3a

**Output shaft seal**

Using a mandrel punch top the output seals out from the housing. Discard seals and replace with a new seal (Fig. 6-3b and Fig. 6-3a item 1).

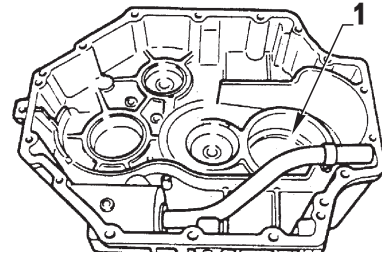

FIG. 6 - 3b

3.6.4 Removal of fluid inlet pipe

For replacing the seal (item 3, Fig. 6-4):

- Remove plate screws (1)
- Remove suction pipe (2)
- Drive out seal (3) after removing dipstick and filter.

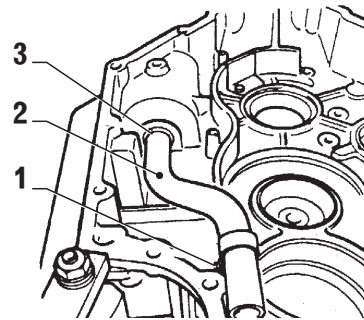

FIG. 6 - 4

3.7 TAPERED ROLLER BEARINGS

Check for failed bearings or excessive bearing wear.

3.7.1 Disassembling the outer races of taper roller bearing

Remove the outer races out of the housing halves by means of the special tool (Fig. 7-1) or by heating the housing halves in an oven to approx. 120°C (248°F). Put the housing in the oven upside down, so the outer races will fall out.

WARNING

Use protective gloves when handling the heated housing and outer races.

IMPORTANT

Regard location of shims under each outer race for correct position during reassembling. Shims are located under outer races of the cover only.

3.7.2 Removal of inner races of taper roller bearings

Input shaft - spline side

The extractor (Fig. 7-2a) is required for pulling the inner races off.

For extracting the inner races proceed as follows:

- insert collet
- place collet onto the roller cage
- tighten collet to rollers by means of cap nut
- screw spindle against shaft and pull bearing evenly and carefully off.

Input shaft - Control block side

The Inner race and the gear on the control block side can be removed by using the split ring and a standard hydraulic press (Fig. 7-2b).

Input shaft - Control block side ZF 85 IV - ZF 80 IV (ZF 85 IV DERIVATE VERSION)

- Remove the retaining ring (item 1, Fig. 7-2c) using a plier.
- Scrap the retaining ring.
- Remove the washer (item 2, Fig. 7-2c).
- Remove the shims (item 3, Fig. 7-2c).

Intermediate and reversal shaft

The inner race of bearings can be drawn off with a commercial extracting unit.

WARNING

Improper use of the extractor when removing the races, could cause damage to the races or slip off.

Output shaft

For extracting the inner races (item 1 and 2, Fig. 7-2d) proceed as follows:

- cut bearing cage (item 3, Fig. 7-2d) open and remove rollers
- place gear on a sleeve
- press output shaft off the gear. Pay attention for pressing-out direction of output shaft Fig. 7-2d.

The bearing inner race (item 1, Fig. 7-2d) will be extracted at the same time.

Extracting force required: approx. 400kN

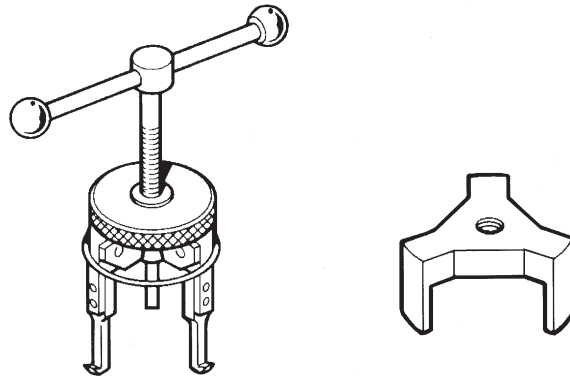

FIG. 7 - 1

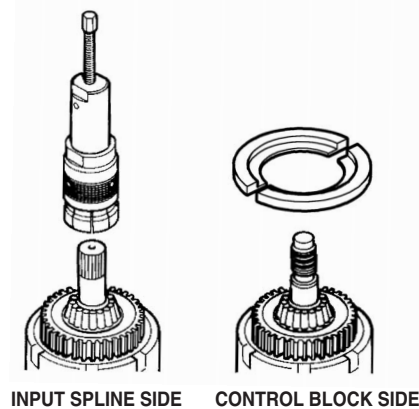

FIG. 7 - 2a

FIG. 7 - 2b

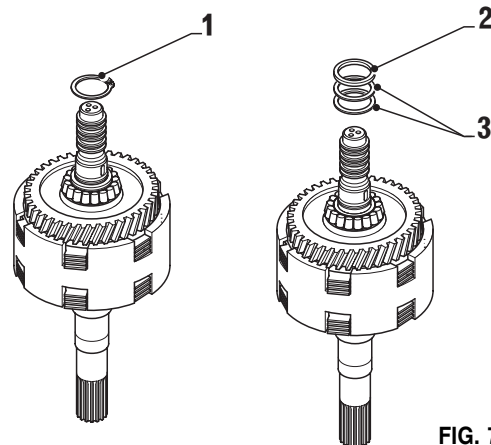

FIG. 7 - 2c

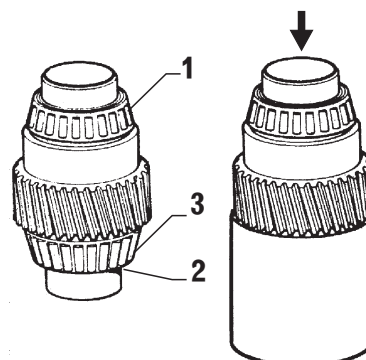

FIG. 7 - 2d



3.8 REVERSING CLUTCH PACK

3.8.1 Removal of the clutch discs

- Remove the tapered roller bearing inner races (item 1 and 2, Fig. 8-1a) and the gear (item 3, Fig. 8-1a) using the tools described in section 2.

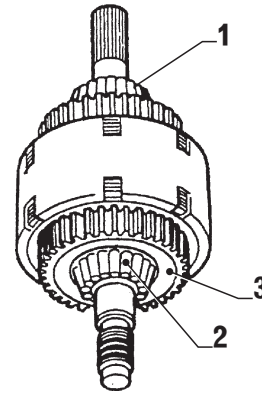

FIG. 8 - 1a

- Lift butting rings (item 1, Fig. 8-1b) off using two screwdrivers.
- Pull gear (item 2, Fig. 8-1b) and needle bearings off.

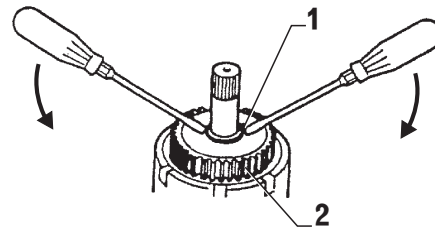

FIG. 8 - 1b

- Removal of pressure plate: Pressing snap ring against periphery of pressure plate (item 1, Fig. 8-1c) by means of screwdrivers. Extract it together with end disc (item 1, Fig. 8-1c). The clutch discs can now be removed from the coupling housing. Repeat same procedure to remove pressure plate on the opposite side.

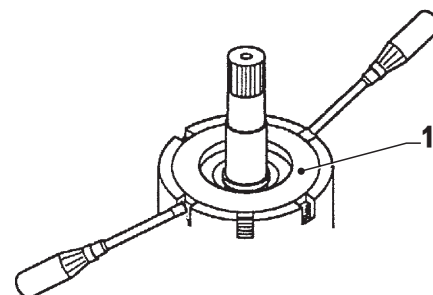

FIG. 8 - 1c



4. ASSEMBLY

INTRODUCTION

A well-lighted work area that is free from dirt and chips, will facilitate the work considerably.

ZF-HURTH MARINE recommends to use a swivelling stand, described in the disassembly section to aid in the assembly.

Thoroughly clean all mating surfaces from any loctite or gasket material.



Cleaners and solvents can be toxic and potentially harmful without proper ventilation.

Use caution when using such cleaners.

Always wear protective gloves and glasses!

The next assembly procedure requires the following:

- An electric oven or heating lamp for heating the housing halves will be required when mounting the bearings.
- A hydraulic or mechanical press

4.1 INPUT SHAFT

4.1.1 Mount discs into reversing clutch

Equip both sides coupling with new outer disc (item 1, Fig. 1-1a) and new inner disc (item 2, Fig. 1-1a).

NOTE

- For exact quantity of inner (item 2, Fig. 1-1a) and outer discs (item 1, Fig. 1-1a), please refer to the spare parts list at the end of this manual.
- Stagger the position of the notches on the outer discs as shown in Fig. 1-1b.

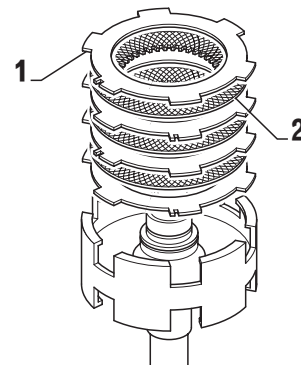

FIG. 1 - 1a

Starting with one of the outer discs, build up the clutch. The lugs on the outer discs have to be positioned in line with each other as shown in Fig. 1-1b.

Install snap ring into groove of clutch housing securing the pressure plate.

Place end disc (item 1, Fig. 1-1c) and snap ring (item 2, Fig. 1-1c) engaging it into clutch housing groove.

Check correct position of end disc (item 1, Fig. 1-1c).

Repeat same procedure on opposite side of clutch (Fig. 1-1d).

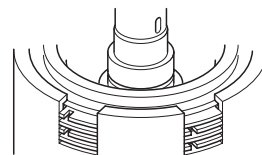

FIG. 1 - 1b

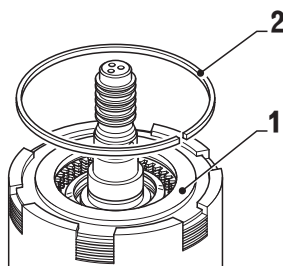

FIG. 1 - 1c

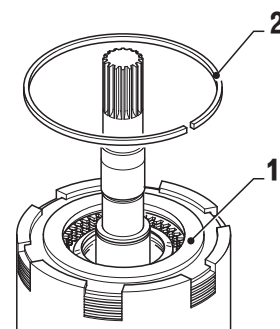

FIG. 1 - 1d

4.1.2 Install needle bearings and gear

Input spline side

- Install needle bearing (item 1, fig. 1-2) onto shaft.
- Slide spacer (item 3, fig. 1-2) where required.
- Align splines on clutch discs previously installed and install gear (item 2, fig. 1-2).

Make sure clutch gear is fully installed, engaging all clutch discs.

Control block side

- Repeat same procedure of input spline.
Spacer is only in ZF 80 IV and ZF 80-1 IV.

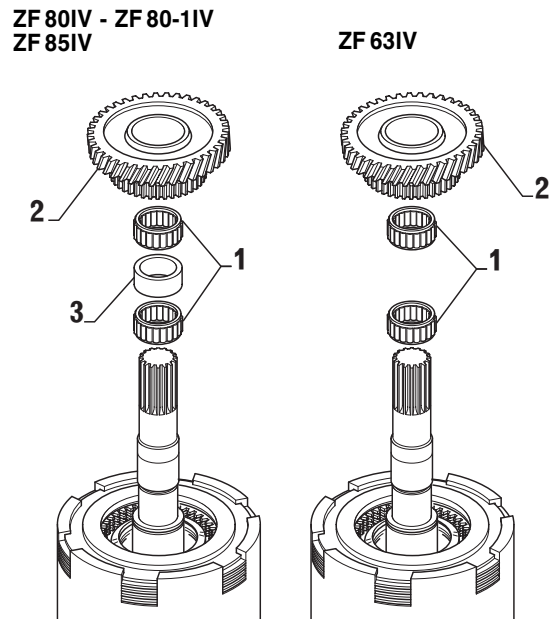

FIG. 1 - 2

4.1.3 Assemble butting rings

Press on new thrust washers (item 1, Fig. 1-3a) onto input shaft.

Make sure thrust washers are fully pressed on and have even contact with gears.

Thrust washers must not be bent. For easier mounting use a tube with a bore dia. of 35 mm (1.38 in).

Repeat same procedure on opposite side (item 1, Fig. 1-3b)

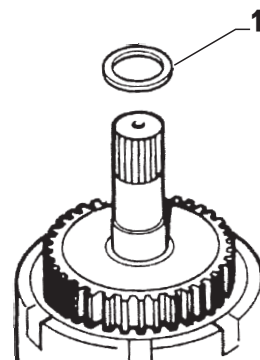

FIG. 1 - 3a

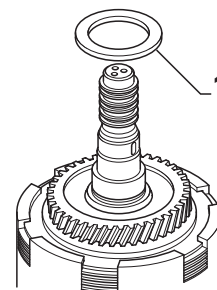

FIG. 1 - 3b



4.1.4 Mounting inner races of tapered roller bearings

Heat inner race of tapered roller bearing (item 1, Fig. 1-4) to approx. 120° (248°F) and push onto input shaft. After cooling down, press bearing carefully against butting ring (item 2, Fig. 1-4) by means of a sleeve and a hydraulic or manual press.

CAUTION

Handle heated tapered roller bearing inner race only with special gloves!

NOTE

For pressing, apply sleeve to inner race but not to rollers.

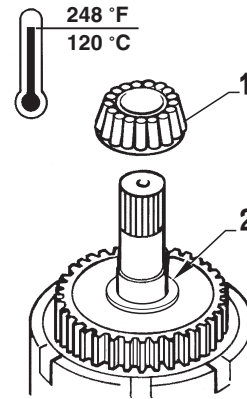

FIG. 1 - 4

4.1.5 Assemble shims, support shims and retaining ring ZF 85 IV - ZF 80 IV (ZF 85 IV DERIVATE VERSION)

- Place the shims (item 1, Fig. 1-5).
- Install the washer (item 2, Fig. 1-5).
- Put the retaining ring (item 3, Fig. 1-5) in the groove of the input shaft using a plier.

WARNING!

- **Correct the shim thickness:** check that there is no slack between washer and the retaining ring.
- **Maximum permissible clearance should be 0.05 mm.** Use a feeler gauge to check it.

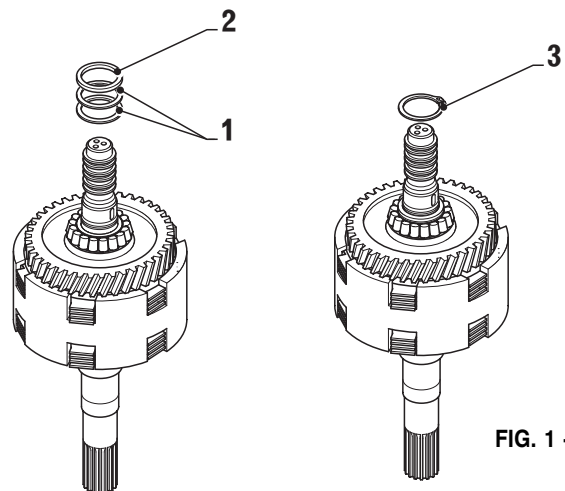

FIG. 1 - 5

4.1.6 Assemble piston rings

Mount piston ring seals (item 1, Fig. 1-6) onto input shaft.

IMPORTANT

Make sure the interlocking position of the piston rings are staggered on the shaft.

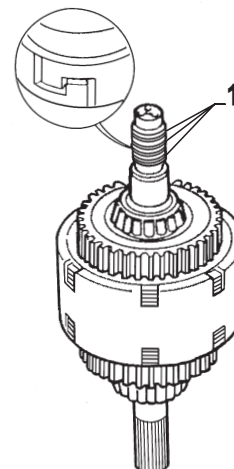

FIG. 1 - 6

4.2 INTERMEDIATE AND REVERSAL SHAFT

4.2.1 Mounting inner races of tapered roller bearings

Heat inner races of tapered roller bearings (item 1 and 2, Fig. 2-1) to approx. 120°C (248°F) and push them onto the intermediate or reversal shaft up against the shaft collar.

WARNING

Handle heated tapered roller bearing inner races only with protective gloves!

When the inner races have cooled down, drive them carefully against the collar using a brass punch.

NOTE

Apply copper/brass punch on inner race and not on the rollers.

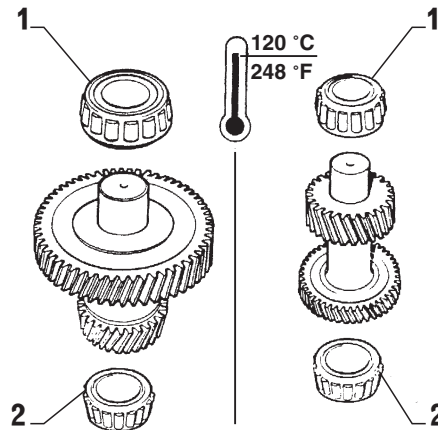

FIG. 2 - 1

4.3 OUTPUT SHAFT

4.3.1 Preparations for assembly

Finish press fit on output shaft and gear with a very fine emery paper. Then clean both parts thoroughly.

WARNING

Cleaners and solvents can be toxic and potentially harmful without proper ventilation. Use caution when using such cleaners.

Always wear protective gloves and glasses!

4.3.2 Mounting inner race of tapered roller bearing

Heat inner races of tapered roller bearings (item 1 and 2, Fig. 3-1) to approx. 120° (248°F) and push them onto output shaft up against shaft collar.

CAUTION

Handle heated tapered roller bearing inner races only with protective gloves!

When the inner races have cooled down, drive them carefully against the collar using a brass punch.

NOTE

Apply copper/brass punch on inner race and not on the rollers.

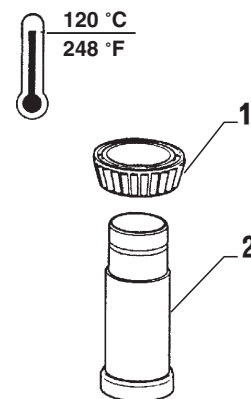

FIG. 3 - 1

4.3.3 Pressing the gear on

ATTENTION

ONLY ZF 63 IV: with transmission ratio of 1.3 to 2.0 the ring (item 1 Fig. 3-2) must be mounted

- Provide press fit of output shaft with a thin coat of glycerol.
- With a transmission ratio of 1.3 to 2.0, a washer (item 1, Fig. 3-2) should be inserted.
- Press gear (item 2, Fig. 3-2) on shaft (item 3, Fig. 3-2), by means of a hydraulic press.

Pressing force required: 200 kN

After having pressed the gear on, mount second inner race of bearing (item 4, Fig. 3-2) as described under 3.2.

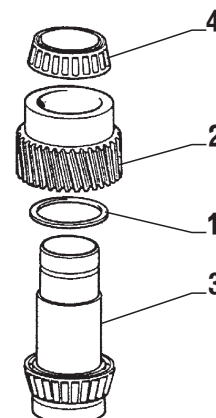

FIG. 3 - 2



4.4 PREASSEMBLY OF HOUSING

4.4.1 Assembly of outer races (tapered roller bearings)

Heat "output" half of the housing (item 1, Fig. 4-1) in an oven to approx. 120°C (248°F).

Insert outer races (item 2, Fig. 4-1) into housing.



WARNING

Handle heated tapered roller bearings outer races on with protective gloves.

When housing has cooled down to ambient temperature, with a press seat outer races carefully into housing.

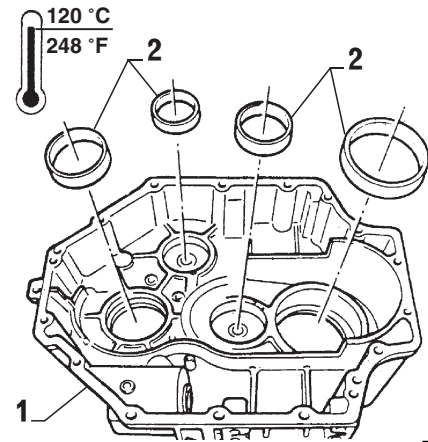

FIG. 4 - 1

4.4.2 Installation of fluid suction pipe

- Position oil suction pipe (item 1, fig. 4-2a) in the housing.
- Put one drop of Loctite 243 into screw threaded hole.
- Lightly tighten the screw (item 2, fig. 4-2a).
- Insert centre square punch and tighten definitely the screw.
- Adjust oil suction pipe to measure "A" (A = 26 mm) (Fig. 4-2b)
- Put some ATF fluid on the seal seat and on the oil suction pipe using a brush.
- Press into housing over the oil suction pipe the seal (item 2, fig. 4-2c) using the appropriate punch (Fig. 4-2c).

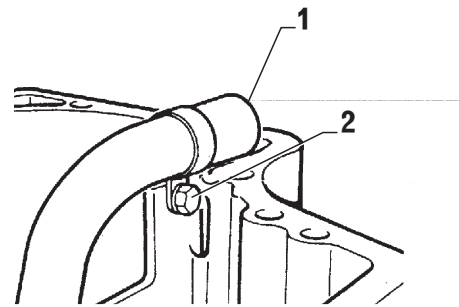

FIG. 4 - 2a

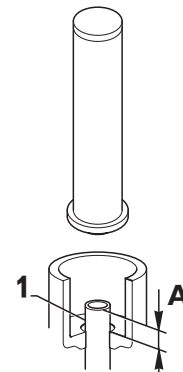

FIG. 4 - 2b

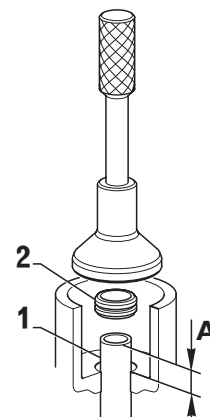

FIG. 4 - 2c

4.4.3 Assembling input shaft seal

Apply thin coat of Loctite 574 on periphery of new radial shaft seal rings (item 1, Fig. 4-3a and items 1-2, Fig. 4-3b) and grease lips with KLUEBER STABURAGS NBU 30.

For transmission ZF 63 IV ratio I = 1.56 only use grease Fa KLUEBER AMBLIGON TA 15/2.

Put a new shaft seal onto the mounting mandrel.

Drive shaft seal uniformly into the housing by tapping slightly onto the mounting mandrel.

NOTE

The sealing lip (A) on the shaft seal should point into the inside of the housing. The radial shaft seal must be adjusted so that the sealing lip does not run on the former running point of the shaft.

Only for transmission size $i = 2.0$ and $i = 2.5$.

The radial shaft seal ring (item 1, Fig. 4-3b) of the input half of the housing can only be mounted after the housing halves have been mounted with the gear set.

ALTERNATIVELY (Fig. 4-3c)

For models ZF 63 IV - ZF 80 IV - ZF 80-1 IV

- Smear Loctite 574 on the outside diameter of the input shaft seal using a roller.
- Lubricate the inside lip with Kluber Staburags NBU30 grease.
- Insert the input shaft seal (item 2) into input shaft using the appropriate bushing p/n 20.0012.01 (item 1).
- Use mandrel p/n 20.0012.02 (item 3) to position the input shaft seal in the correct way.

For models ZF 85 IV - ZF 80 IV (ZF 85 IV DERIVATE VERSION)

- Smear Loctite 574 on the outside diameter of the input shaft seal using a roller.
- Lubricate the inside lip with Kluber Staburags NBU30 grease.
- Insert the input shaft seal (item 2) into input shaft using the appropriate mandrel p/n 20.1072.01 (item 1).
- Position the input shaft seal in the correct way.

4.4.4 Mounting the breather filter

NOTA

Due to the taper thread, the breather (item 1, Fig. 4-4) do need not to be coated with Loctite 243.

Apply thin coat of Loctite 574 to the breather (item 1, Fig. 4-4).

Tighten **carefully** during assembly (hand-tight).

Check leakage during a later test run. Retighten slightly if it leaks.

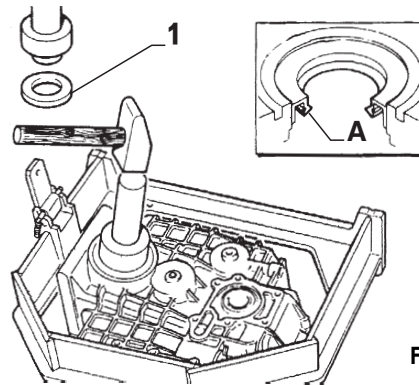

FIG. 4 - 3a

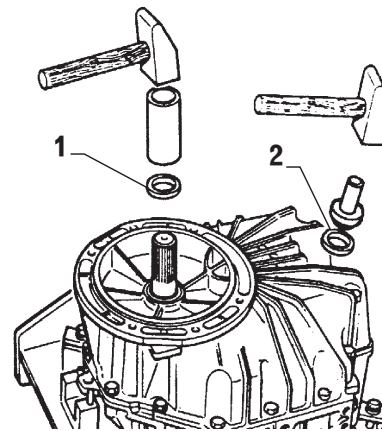

FIG. 4 - 3b

ZF 63IV - ZF 80IV
ZF 80-1IV

ZF 85IV - ZF 80IV
(ZF 85IV DERIVATE VERSION)

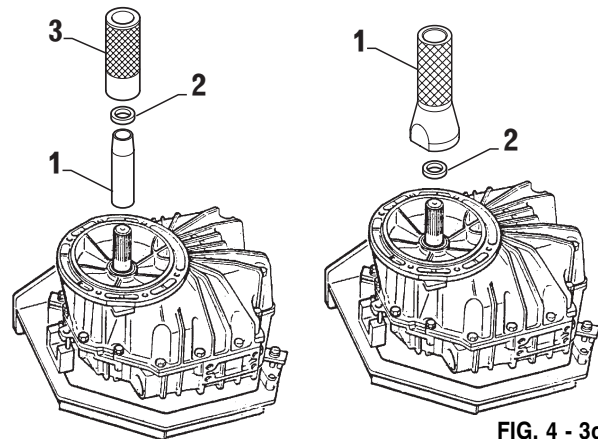

FIG. 4 - 3c

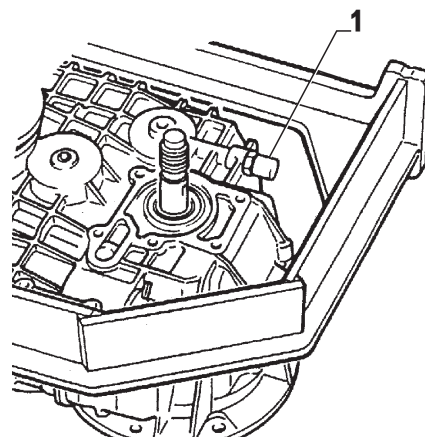

FIG. 4 - 4



4.5 MEASURING THE BEARING CLEARANCE/ADJUSTING THE PRETENSION OF BEARINGS

4.5.1 General

The required pretention of bearings of the individual shafts in the housing is obtained by using shims of different thickness under the outer races of the taper roller bearings.

Shims which have been removed during disassembly may be reused.

First adjustment must refer to bearing clearance.

Take out at least shims of 0.2 mm (0.0079 in.) thickness from the shims packages which were removed during disassembly.

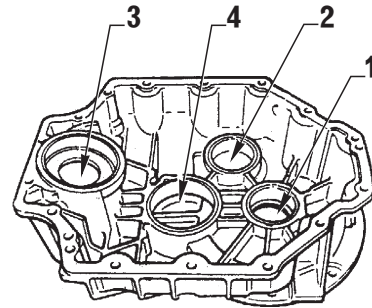

FIG. 5 - 1

ZF 63 IV - ZF 80 IV - ZF 80-1 IV - ZF 85 IV

Pretension	Input	Intermdial/reversal	Output
mm	0.02 - 0.12	0.00 - 0.12	0.05 - 0.15
inches	0.000787 - 0.00472	0.00 - 0.00472	0.001968 - 0.00591

4.5.2 Mounting outer races of tapered roller bearings into housing

Heat "input" half of the housing (item 1, Fig. 5-2) in an oven to approx. 120°C (248°F); insert shims (item 2) and outer races (item 3) of bearings into the housing (Fig. 5-2).



WARNING

Handle heated housing half only with protective gloves!

When housing half has cooled down to ambient temperature, press outer races carefully up to stop of housing half using a press.

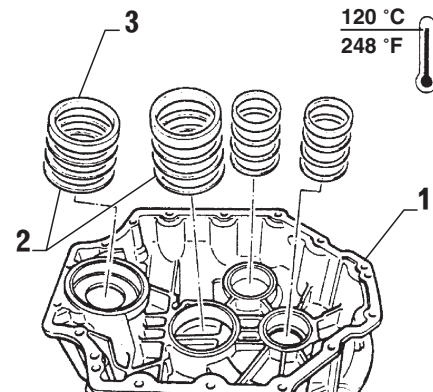

FIG. 5 - 2

4.5.3 Inserting gear set into housing

Finish housing mating facehalves with an oilstone or a fine finishing file.



CAUTION

Make sure to keep any dirt out of housing.

- Insert gears into housing
- Mount "input" housing half (item 1, Fig. 5-3) with all bolts, lock washers (item 2 and 3, Fig. 5-3) and parallel pins (item 4, Fig. 5-3).
Tightening torques of bolts: 40 Nm (30 ft. lb.)

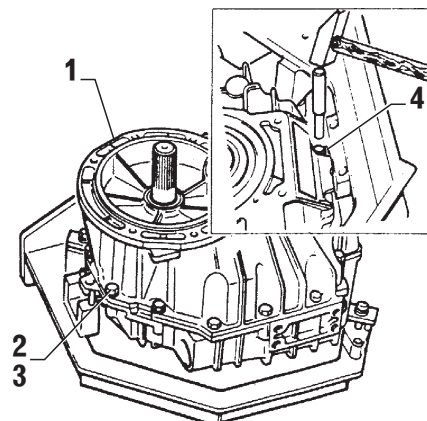

FIG. 5 - 3

4.5.4 Measuring bearing clearance on input shaft

- a) Turn input shaft several times to permit bearings to seat.
- b) Fit clamping ring (tool p/n 319.354.3 (618582) to the spline of the input shaft (item 1, Fig. 5-4).
- c) "0" dial indicator to obtain accurate reading.
- d) With two levers carefully pry on the clamping ring and record end play of shaft.
This step must be done very carefully to obtain the actual bearing clearance.

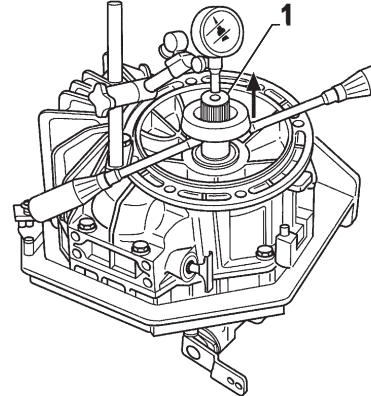

FIG. 5 - 4

NOTE

This step must be done very carefully to obtain the actual bearing clearance.

- e) Carry out steps "a" and "d" for several times.
- f) The bearing clearance measured plus the pretension required in section 5.1 will determine the required thickness of shims.
Round off the determined shims thickness to 0.05 mm (0.001968 in.).

4.5.5 Measuring bearing clearance at intermediate and reversal shafts

- a) Unscrew plug (item 1, Fig. 5-5a) from the housing.
- b) Screw bolt (tool no. 224.836.008 - 458105) (item 2, Fig. 5-5a) into intermediate shaft.
- c) Mount dial gauge support securely onto housing.
- d) Turn intermediate shaft several times to permit bearings to seat.
- e) Adjust the dial indicator needle on top of the bolt head, and "0" indicator (Fig. 5-5b).
- f) Screw hexagon nut carefully against housing flange until bearing clearance is overcome (Fig. 5-5b).

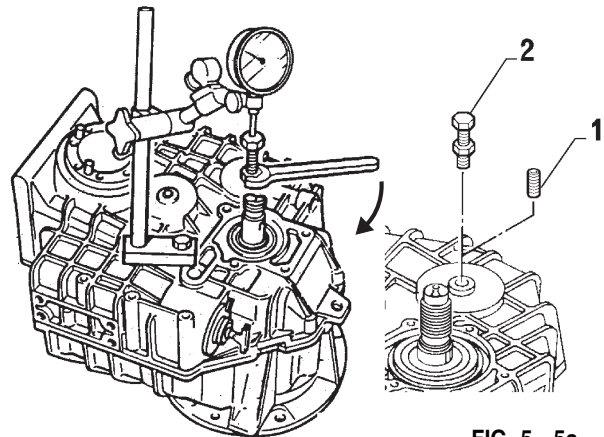

FIG. 5 - 5a

NOTE

This step should be done very carefully to obtain the actual bearing clearance.

- g) Carry out Steps "d" and "f" for several times.
- h) The bearing clearance measured plus the pretension required in section 5.1 will determine the required thickness of shims.

NOTE

Round off the determined shimr thickness to 0.05 mm (0.001968 in.).

- i) Unscrew bolt with nut and remove dial gauge with support.
- l) Repeat same procedure for reversal shaft.

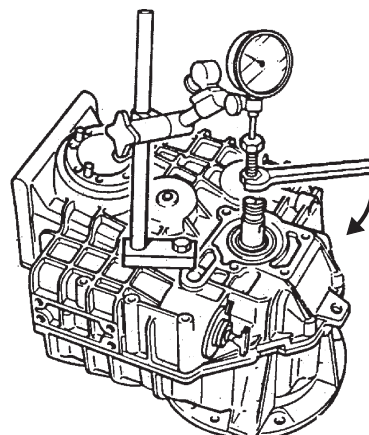

FIG. 5 - 5b



4.5.6 Measuring the bearing clearance on the output shaft

- a) Mounting the output flange.
 Drive parallel pins (item 1, Fig. 5-6a) into output flange (item 2, Fig. 5-6a).
 Screw output flange with socket head bolts (item 3, Fig. 5-6a) on output shaft.
 Tightening torque:
 32 Nm (23.6) ZF 63 IV;
 100 Nm (73.8 ft.lb.) ZF 80 IV - ZF 80-1 IV - ZF 85 IV.
- b) Turn output shaft repeatedly to permit bearings to seat.
- c) Mount dial gauge support securely onto housing, and "0" indication gauge.
- d) Place dial gauge onto bolt head.
- e) Lift output shaft carefully, using two screwdrivers, and record measurement (Fig. 5-6b).

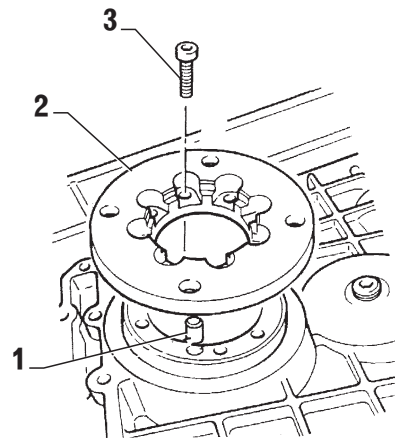

FIG. 5 - 6a

NOTE

This step should be done very carefully to obtain the actual bearing clearance.

- f) Carry out steps "b" and "e" for several times.
- g) The bearing clearance measured plus the pretension required in section 5.1 will determine the required thickness of shims.

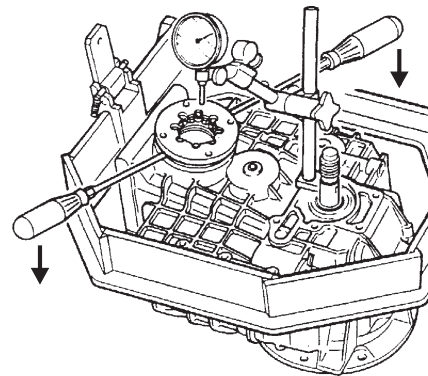

FIG. 5 - 6b

NOTE

Round off the determined shim thickness to 0.05 mm (0.001968 in.).

- h) Unscrew bolt with washer and dial gauge with support.

4.5.7 Adjusting the pretension clearance of bearings

When the thickness of shims has been determined, the transmission must be disassembled again.

- a) Unscrew output flange (see Fig. 5.6a).
- b) Using a adequate drift punch, drive the parallel pins (item 1, Fig. 5-7a) with slight blows out of the housing.
- c) Loosen hex bolts with lockwashers (items 2 and 3, Fig. 5-7a) and remove input side of housing (item 4, Fig. 5-7a).
- d) Remove gears from the housing (Fig. 5-7b).

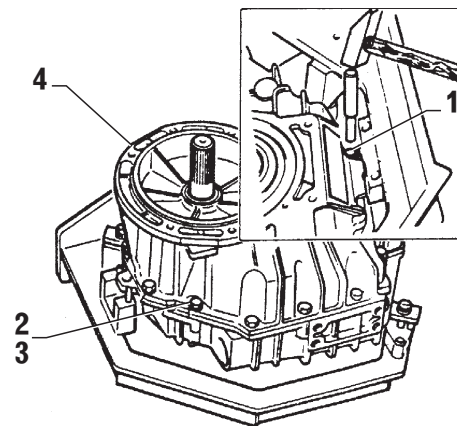

FIG. 5 - 7a

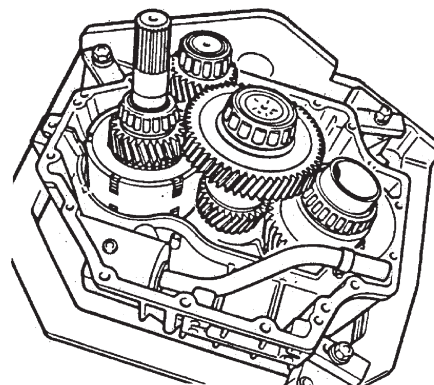

FIG. 5 - 7b

- e) Pull outer races of bearings out of the "drive" housing half using the extracting unit (Fig. 5-7c) or heat the half of the housing in an oven to approx. 120°C (248°F) and remove the outer races of bearings together with shims.

WARNING

Handle heated housing half and outer race only with protective gloves!

NOTE.

Make sure to keep the shims with each outer race and not mix them together.

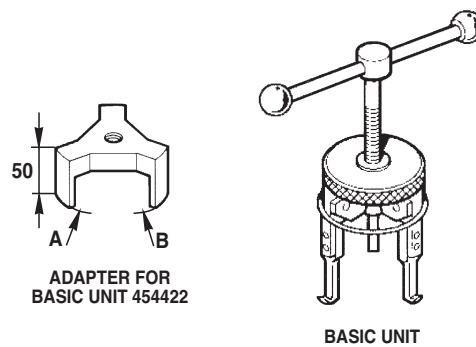

FIG. 5 - 7c

4.5.8 Final assembly of the housing

- a) Heat input side of the housing in an oven to approx. 120°C (248 °F).

WARNING

Handle heated housing only with protective gloves!

- b) Insert the required shims for proper pretension into bearings bore under bearing outer race.
- c) Insert outer races of bearings. When the housing half has reached ambient temperature, drive outer races of bearings up to the stop, using a copper punch.
- d) Insert gears again.
- e) Fill space between seal and dust lips of shaft seal rings with a high quality bearing grease (KLUEBER STABURAGS NBU 30).
- f) Apply a thin coat of Loctite 518 on mating face of "input" housing half and join both housing halves.

WARNING

The necessary time for a complete polymerization is 5 hours: we recommend therefore to clean carefully the mating surfaces with Loctite 7063 cleaner before applying the Loctite 518 and wait the requested time before the spin test.

- g) Drive parallel pins into housing to align housing halves, before tightening.
- h) Apply Loctite 243 on to mounting bolts (item 2 and 3, Fig. 5-7a) and torque them to 40 Nm (30 ft lb).
- i) Check pretension of bearings according to sections 5.4, 5.5 and 5.7.

CAUTION

There must be no measurable bearing clearance.

- j) Only for transmission size $i = 2.0$ and $i = 2.5$ ZF 63 IV. Press radial shaft seal (item 1, Fig. 4-3b) with a suitable pipe into the "drive" housing half.

NOTE

The sealing lip on the radial shaft seal show to the inside of the housing. The radial shaft seal must be so adjusted that the sealing lip does not bear on the former running point of the shaft.

- k) Mount the output flange again. (see chapter 5.6).



4.6 CONTROL BLOCK

4.6.1 Mounting the control block

New piston rings (item 1, Fig. 6-1) have already been assembled according to section 4.1.5.

- a) Insert key (item 2, Fig. 6-1) into groove of shaft.
- b) Place new gasket (item 3, Fig. 6-1) onto control block.
- c) Key slot in pump-drive wheel should be aligned (Fig. 6-1).
- d) Slide control block carefully on input shaft.
- e) Push lock washers (item 4, Fig. 6-1) on socket head bolts (item 5, Fig. 6-1) and provide screw threads each with a drop of Loctite 243.
- f) Screw control block tight. Tightening torque of screws: 18 Nm (13 ft.lb.).

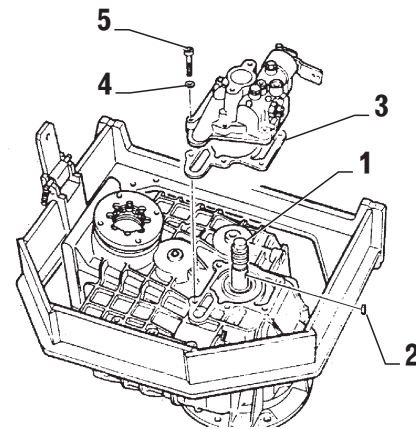

FIG. 6 - 1

4.7 FLUID FILTER

4.7.1 Mounting the fluid filter

- Wet O-rings (item 1 and 2, Fig. 7-1) with some ATF fluid and mount them.
- Install filter element (item 3, Fig. 7-1) into the transmission.
- Lock cover (item 4 Fig. 7-1) to the transmission using an allen wrench. Tightening torque: min. 5 Nm - max 8 Nm (min. 4 ft.lb. - max 6 ft.lb.)

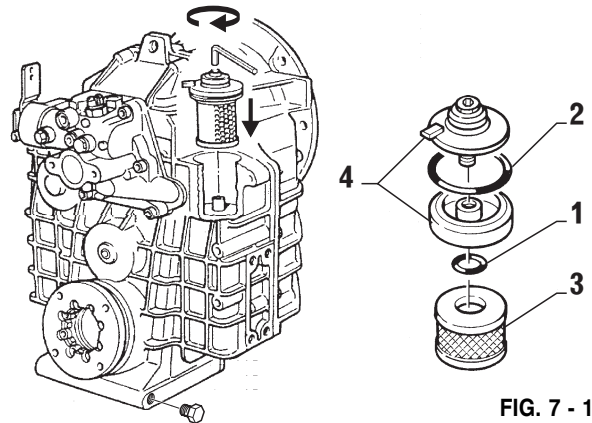

FIG. 7 - 1

4.8 MAKING THE TRANSMISSION READY FOR OPERATION

4.8.1 Filling up with Transmission Fluid

Filling with ATF fluid into the dipstick opening (Fig. 8-1). ATF (Automatic Transmission Fluid) such as, per list on chapter X.

Fluid quantity:

ZF 63 IV:	4.4 liters (1.1 US gallons)
ZF 80 IV - ZF 80-1 IV:	7.0 liters (1.85 US gallons)
ZF 85 IV:	7.0 liters (1.85 US gallons)

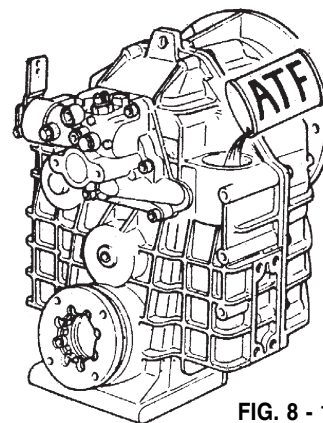

FIG. 8 - 1

4.8.2 Inserting fluid filter into housing

Insert fluid filter into housing and tighten clockwise by hand. (Fig. 8-2).

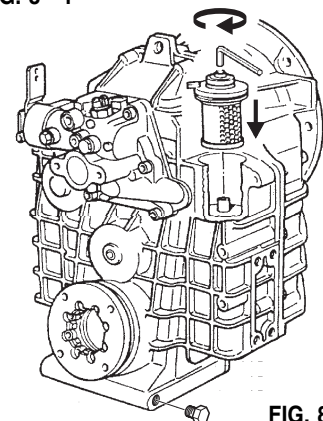

FIG. 8 - 2

4.8.3 Check fluid level

Carry out a trial run after oil filling.

Set shifting lever to neutral position (N).

Start engine and let it run idle for a short time to fill the cooler and pipelines with transmission oil.

Stop the engine and check oil level again. If necessary, top up with oil. Excessive oil should be removed.

The fluid level on the dipstick (item 1, figure 8-3) should be between the min. and max. marks.

The fluid level should be checked again after a short driving period.

NOTE

Some transmissions may have different oil dipsticks, depending on the version:

A) When inserted into the housing hole, it expands by turning the handle in clockwise direction.

(Fig. 8-3 item A)

B) It is threaded (Fig. 8-3 item B).

IMPORTANT

Oil check with threaded dipstick (B) must be done in a different way compared with the one not threaded (A):

A) Oil dipstick and housing hole not threaded: dipstick completely inserted into hole.

B) Oil dipstick and housing hole threaded: dipstick not inserted into the housing hole (not screw in).

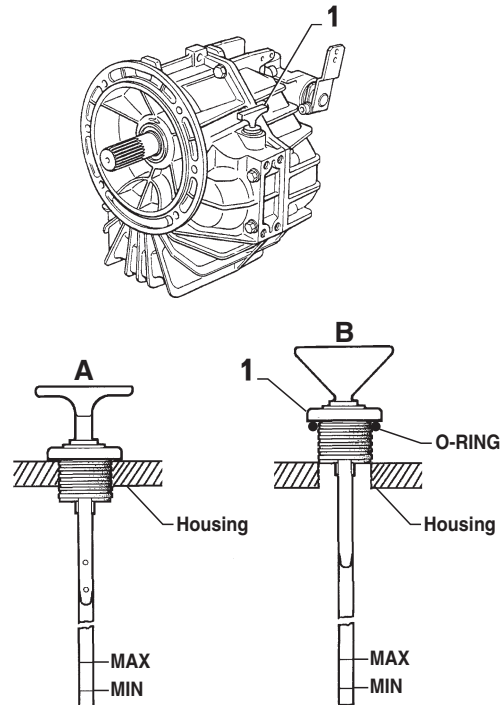

FIG. 8 - 3



5. ADJUSTMENT DATA

5.1 SHIFTING PRESSURE

5.1.1 ZF 80-1 IV - ZF 85 IV - ZF 80 IV (ZF 85 IV DERIVATE VERSION); mechanical selector valve 26 bar p/n 3313 108 001

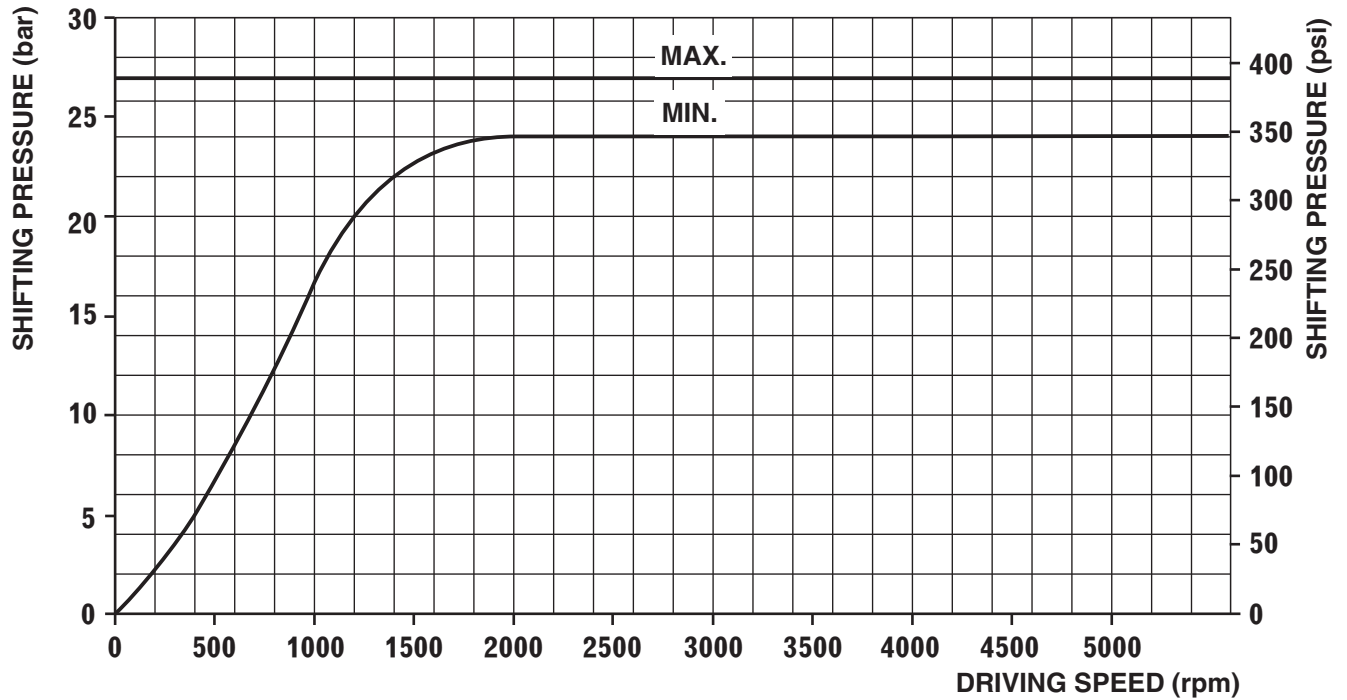

5.1.2 ZF 63 IV - ZF 80 IV VERSION; mechanical selector valve 23 bar p/n 3312 108 001

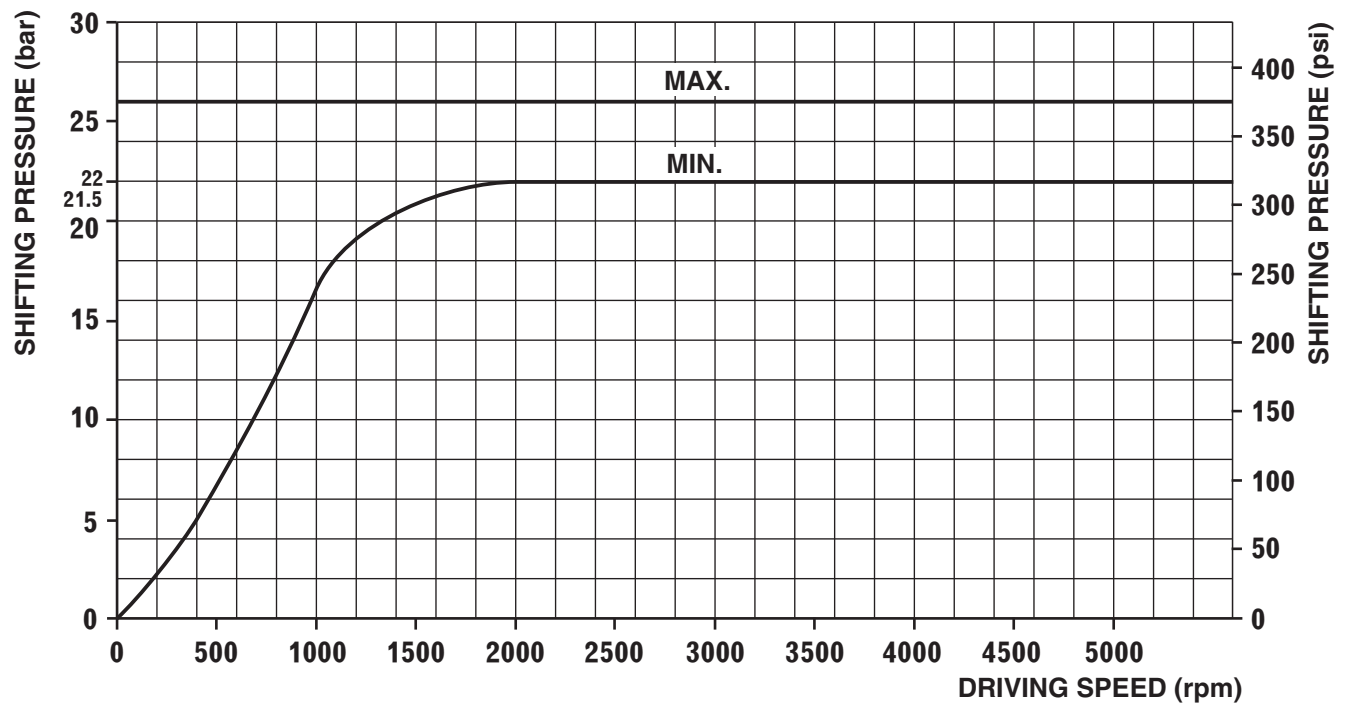



5.1.3 ZF 63 IV INDMAR VERSION; mechanical selector valve 21 bar p/n 3312 108 003

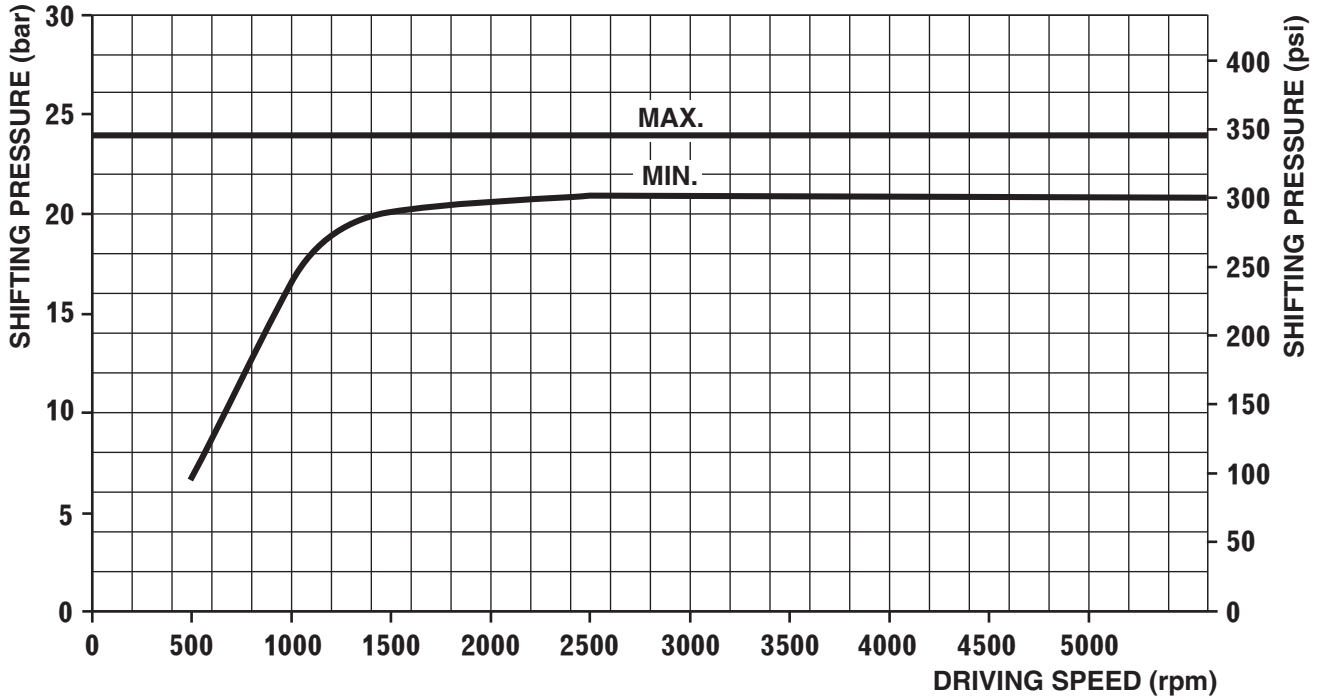

5.2 LUBE OIL DELIVERY RATE

5.2.1 ZF 80-1 IV - ZF 85 IV - ZF 80 IV (ZF 85 IV DERIVATE VERSION); mechanical selector valve 26 bar p/n 3313 108 001

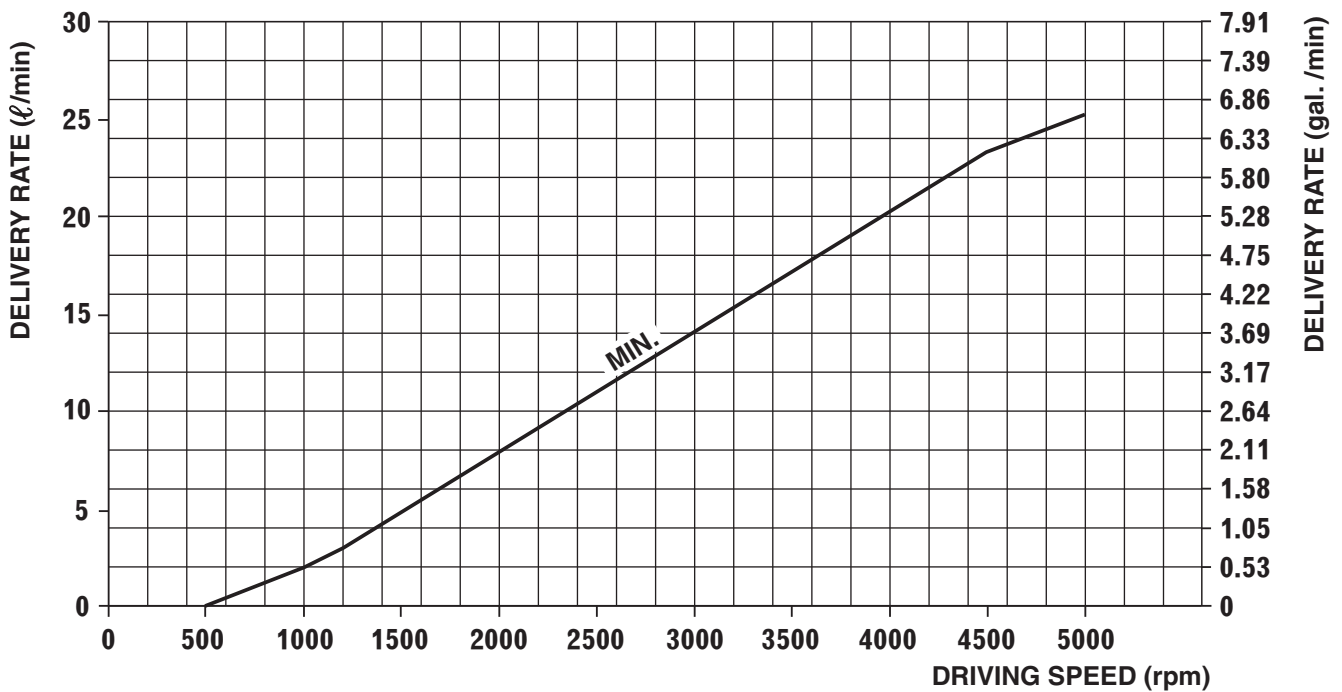



5.2.2 ZF 63 IV - ZF 80 IV VERSION; mechanical selector valve 23 bar p/n 3312 108 001

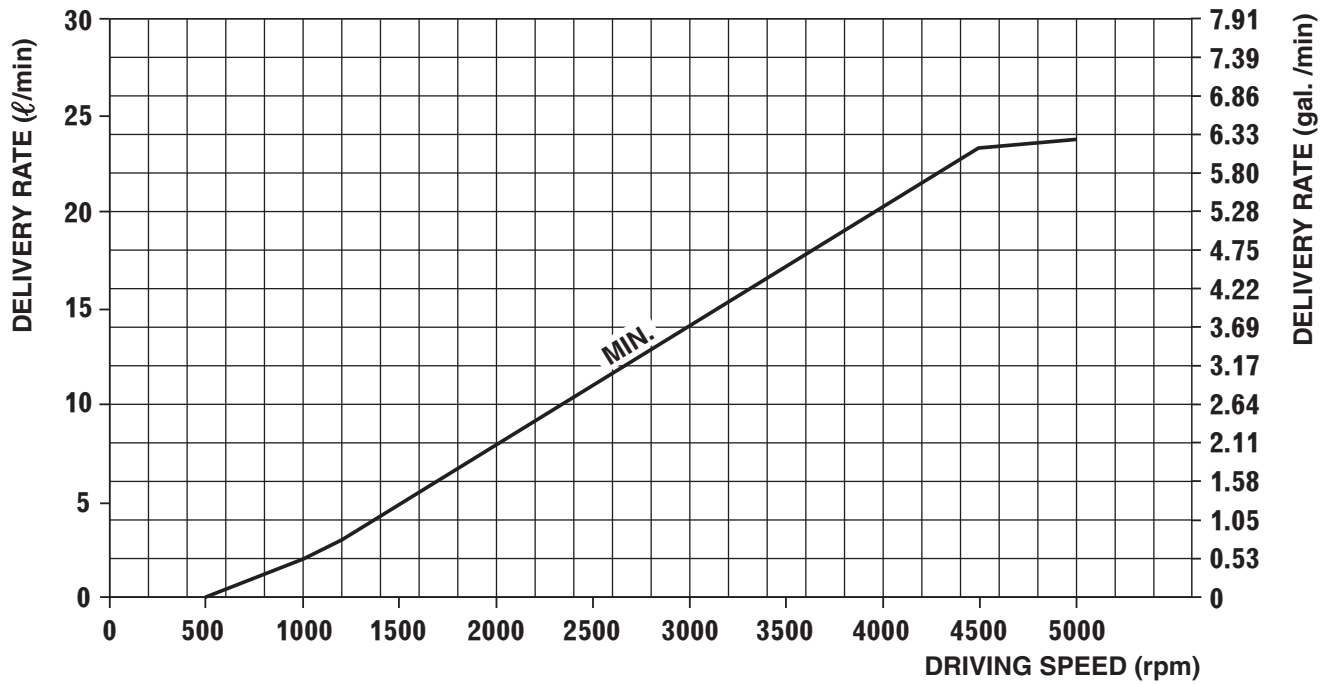

5.2.3 ZF 63 IV INDMAR VERSION; mechanical selector valve 21 bar p/n 3312 108 003

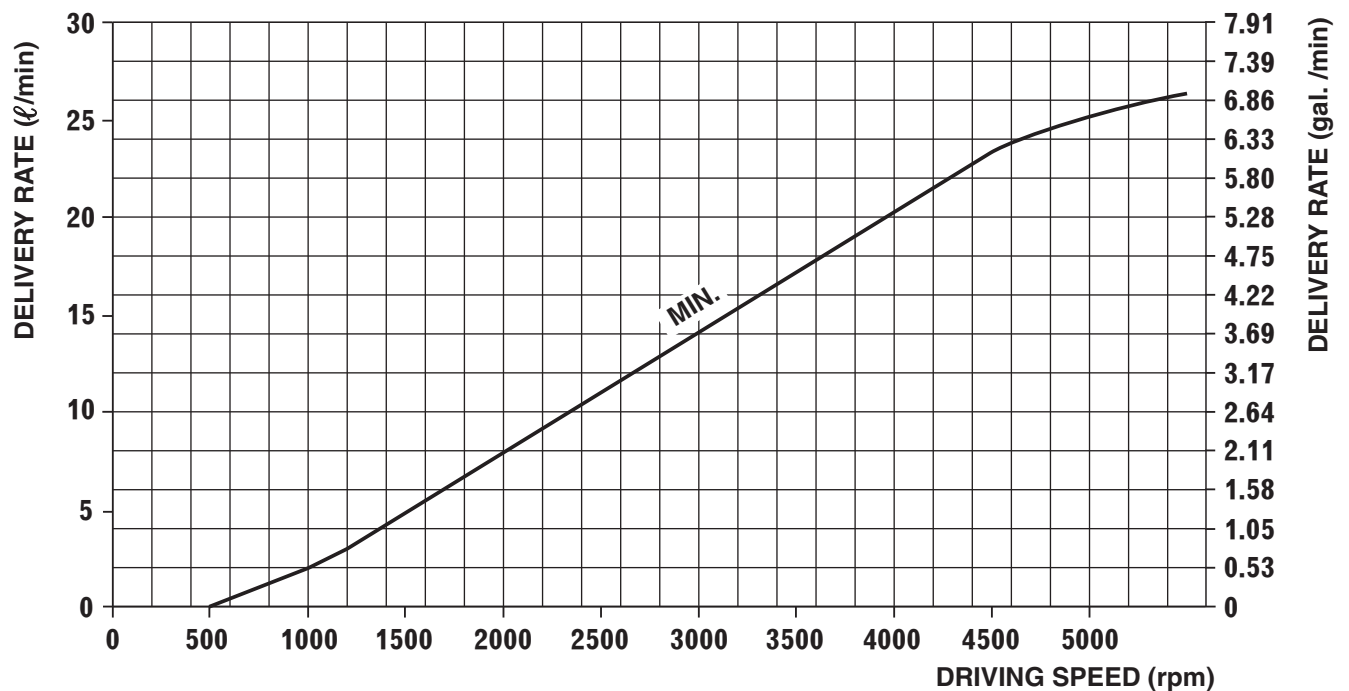

6. HYDRAULIC DIAGRAM

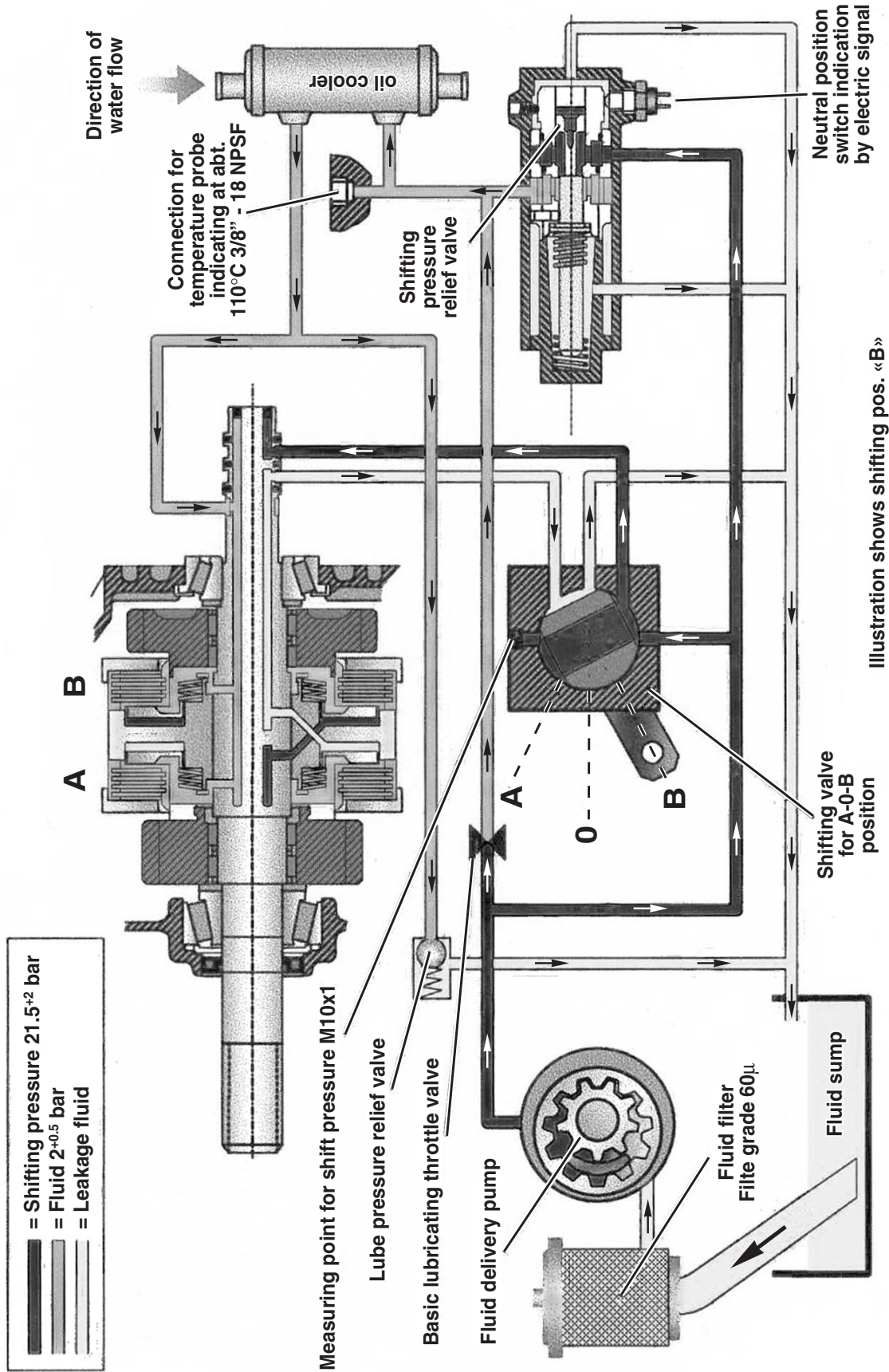



7. TIGHTENING TORQUES

PART	SIZE	TORQUE IN lb.ft.	TORQUE IN Nm	LOCTITE
Mounting bracket bolts ZF 63 IV	M12	min. 55.5 - max. 57	min. 75 - max 77	—
Mounting bracket bolts ZF 80 IV, ZF 80-1 IV, ZF 85 IV	M12	min. 55.5 - max. 57	min. 75 - max 77	—
Housing bolts	M10	30	40	—
Output flange bolts ZF 63 IV	M8	24	32	243
Output flange bolts ZF 80 IV - ZF 80-1 IV - ZF 85 IV	M12	74	100	243
Control block bolts	M8	13	18	243
Shifting lever bolt	M8	17	23	—
Stud bolts	M16	26	35	243
Screw	M5	4	5	243
Oil drain plug	—	30	40	243
Oil breather	—	Hand tight	Hand tight	574
Fluid dipstick	—	Hand tight	Hand tight	—
Filter cover screw	M8	min. 4 - max. 6	min. 5 - max. 8	—
Control block stop screw	—	9	12	—
Control block pressure screw	M10	9	12	—
Neutral safety switch	-	18.5	25	—
Control block guide bolt	-	9	12	—
Control block temperature plug	-	26	35	—



8. FUNCTION TEST

When the transmission has been completely assembled and filled up with transmission fluid, it would be convenient to make a function test.

This test can be carried out on a bench test rig, or in a boat. If no fluid cooler can be connected, a hydraulic hose must be connected between the inlet and outlet of the hydraulic pump.

Measuring instruments required:

- Pressure gauge 0-40 bar (0-580 psi), with connecting thread M10x1
- Temperature gauge 0-120°C (0-250°F), connecting thread 3/8"-18NPSF
- Flow meter 0-35 liters/min (0-10 gals/min)

Tests to be carried out:

1. Fluid leaks
2. Noise emission
3. Direction of rotation, LH/RH
4. Lube oil temperature
5. Shifting pressure
6. Lube oil flow rate

The function test should be carried out follows:

Motor speed (rpm)	Shift lever position	Durat. minutes	Test
800-1000	neutral	5	1, 2
600-800 (idling speed)	A <-> B position repeatedly	-	1, 2, 3
1500-2500	B position	-	1, 2, 4
600-800 (idling speed)	A <-> B position repeatedly	-	1, 2, 3
idling - max. speed	A position	-	1, 2, 5**, 6**
600-800 (idling speed)	A-> B position	-	1, 2
idling - max. speed	B position	-	1, 2, 5**, 6**

* Until a fluid temperature of 75-80 °C (167-176°F) has been reached

** At different speeds.



9. TROUBLESHOOTING

In case of trouble, first check whether all recommended mounting and operating instructions have been completed. The subsequent tables will assist you in troubleshooting and finding solutions. If any adjustments are necessary on the transmission, please reference the Repair Manual. Warranty claims will be forfeited if work on the transmission is performed by unauthorized persons during the warranty period.

Symptom	Possible cause	Remedy
1. Transmission cannot be shifted.	1.1 Shifting lever is loose. 1.2 Remote control does not permit lever travel required for testing. 1.3 Remote control faulty. 1.4 No shifting pressure available.	1.1 Tighten clamping bolt on shifting lever 1.2 Lift remote control off, if gears can be shifted by hand, correct remote control. 1.3 Repair remote control. 1.4 Refer to 7.
2. Delayed shift.	2.1 Shift linkage time misadjusted; not allowing full engagement.	2.1 Lift remote control off, if gear can be shifted by hand, correct remote control. If the transmission cannot be shifted correctly by hand, replace the control block.
3. Clutch is slipping, i.e. propeller speed too low as compared to engine speed.	3.1 Inadmissible fluid used. 3.2 Fluid contains water. 3.3 Shifting pressure too low. 3.4 Wear on clutch discs. 3.5 Piston rings in clutch are damaged.	3.1 Drain fluid, refill with prescribed fluid, flush transmission while engine runs in neutral position, drain fluid, refill transmission. 3.2 Refer to 9. 3.3 Refer to 6. 3.4 Disassemble transmission, replace clutch discs. 3.5 Disassemble transmission, replace clutch.
4. Transmission locked in gear.	4.1 Medium piston ring in input shaft in control block is faulty. 4.2 Warped discs due to over heating of slipping clutch. 4.3 Needle bearings on input shaft are worn out.	4.1 Remove control block, replace piston ring, if control block is worn, replace likewise. 4.2 Refer to 3. 4.3 Disassemble transmission, replace clutch.
5. Output shaft turns in neutral position.	5.1 Rotary slide valve in block control block is worn. 5.2 Faulty needle bearing on input shaft. 5.3 Warped discs due to overheating of slipping clutch.	5.1 Replace control. 5.2 Disassembly transmission and input shaft, replace bearing concerned and other damaged parts. 5.3 Refer to 3.
6. Shifting pressure too low.	6.1 Fluid filter dogged. 6.2 Fluid level in transmission. 6.3 Fluid pump is worn out. 6.4 Spring in shifting pressure relief valve is broken. 6.5 Piston rings on input shaft are faulty. 6.6 Piston rings in clutch are faulty.	6.1 Replace fine filter. 6.2 Top-up with fluid; in case of fluid loss check transmission, cooler and pipelines for leakage and remedy same; also refer to 10. through 13. 6.3 Replace control block containing fluid pump. 6.4 Replace control block. 6.5 Remove control block and replace piston rings. In case of wear in control block due to faulty piston rings replace block as well. 6.6 Disassemble transmission, replace clutch.



Symptom	Possible cause	Remedy
7. No shifting pressure available.	7.1 Direction of engine rotation does not agree with arrow on transmission. 7.2 No fluid in the transmission. 7.3 Fine filter is dirty. 7.4 Fluid level in transmission is too low. 7.5 Fluid pump worn out. 7.6 Fitting key in input shaft for fluid pump drive is broken. 7.7 Spring of shifting pressure control block relief valve is broken.	7.1 Replace with engine of correct of rotation. 7.2 Refill with fluid. 7.3 Replace fine filter. 7.4 Top-up with fluid. In case of loss of fluid check transmission, cooler and pipelines for leakage and remedy same, also refer to 10. through 13. 7.5 Replace control block. 7.6 Remove control block. 7.7 Replace fitting key, replace any other faulty parts.
8. Excessive fluid temperature.	8.1 Fluid cooler is too small. 8.2 Excessive fluid in transmission. 8.3 Fluid cooler is dirty on water side. 8.4 Worn fluid pump in control block. 8.5 Faulty piston rings in control block. 8.6 Clutch is slipping. 8.7 Clutch does not open completely due to worn disc support. 8.8 Clutch does not open completely due to worn disc support. 8.9 With fluid cooler in bypass and unfavorable arrangement of pipelines too little coolant water flows through bypass to cooler.	8.1 Use a larger fluid cooler. 8.2 Remove excessive fluid with commercial suction pump. 8.3 Detach coolant water lines and clean fluid cooler on water side. 8.4 Replace control block containing fluid pump. 8.5 Remove control block, replace piston rings. In case of wear in the control block due to faulty piston rings replace control block as well. 8.6 Refer to 3. 8.7 Dismount transmission and coupling, replace all faulty parts. 8.8 Dismount transmission, replace inner disc support and/or clutch. 8.9 Correct bypass pipeline.
9. Water in the fluid, fluid looks milky.	9.1 Fluid cooler faulty. 9.2 High water level in engine compartment, water entering through output shaft seal.	9.1 Repair leakage at cooler or replace cooler. Change transmission fluid. 9.2 Remedy cause for water level in engine compartment change transmission.
10. Fluid leakage at output shaft.	10.1 Breather clogged with paint or dirt. 10.2 Shaft seal faulty.	10.1 Remove paint or dirt from breather. 10.2 Disassemble transmission, replace seal. If seal location on output shaft is worn-seal lip should be mounted offset.
11. Fluid leakage at breather.	11.1 Excessive fluid in transmission.	11.1 Pump excessive fluid out with commercial hand pump.
12. Fluid leakage at joints.	12.1 Bolts are not tight. 12.2 Seals on bolts have been used several times. 12.3 Mating faces are contaminated, no surface seal applied.	12.1 Tighten bolts with prescribed torque. 12.2 Replace seals, tighten bolts with prescribed torque. 12.3 Unscrew housing half, finish mating faces with oilstone or finishing file, apply surface seal. Assemble transmission, tighten bolts with correct torque.



Symptom	Possible cause	Remedy
13. Transmission noise becomes louder.	13.1 Fluid level too low so that pump sucks in air. 13.2 Damage starting on flexible coupling due to wear or fatigue, possible due to misalignment between engine and transmission. 13.3 Beginning damage of bearings in transmission, e.g. due to torsional vibrations, running without fluid, overload, wrong alignment of transmission excessive engine output. 13.4 Beginning damage of gearings, e.g. due to torsional vibrations, running without fluid, overload. 13.5 Fluid suction pipe in transmission has come loose.	13.1 Top up with fluid to marking on dipstick. 13.2 Replace flexible coupling. Check alignment between engine and transmission. 13.3 Disassemble transmission, replace bearings concerned and other faulty parts. Find causes and remedy. 13.4 Disassemble transmission, remove faulty parts. 13.5 Disassemble transmission, fix fluid suction pipe.
14. Chattering transmission noise mainly at low engine.	14.1 The engine or propeller generate torsional vibrations in the drive unit which produce a "chattering" noise in the transmission. 14.2 Misaligned cardan shafts on input or output.	14.1 Mount a flexible coupling with another stiffness factor between engine and transmission; a coupling with a higher stiffness factor might be sufficient. Otherwise analyse the torsional vibrations to find out the required stiffness for the coupling. 14.2 Mount and align cardan shaft strictly according to instructions issued by cardan shaft manufacture.
15. Low pressure	15.1 Fine filter is dirty. 15.2 Fluid level in transmission is low. 15.3 Control block is broken. 15.4 Problem at control valve. 15.5 Piston rings on input shaft are faulty. 15.6 Piston rings inside the clutch are faulty. 15.7 Defective cover filter : air suction. 15.8 Oil suction hose not properly adjusted. 15.9 Fitting key in input shaft for fluid pump drive is broken. 15.10 Possible wear of the piston ring grooves.	15.1 Replace fine filter. 15.2 Refill with fluid. 15.3 Replace control block. 15.4 Replace control block. 15.5 Remove control block and replace piston rings. 15.6 Disassemble transmission, replace piston rings. 15.7 Replace cover filter. 15.8 Replace the seal and adjust correctly the suction hose. 15.9 Remove control block replace fitting key, replace any other faulty parts. 15.10 Replace the input shaft.
16. Oil leakage.	16.1 Porosity. 16.2 Seals. 16.3 Joints. 16.4 Bracket with flatness error. 16.5 Bolts are not tight. 16.6 Fittings loosen. 16.7 Dipstick is not tight. 16.8 Filter is not tight. 16.9 Excessive fluid in transmission. 16.10 Breather clogged with paint or dirt (fluid leakage at output shaft). 16.11 Aluminium washers used more times.	16.1 Replace faulty parts. 16.2 Replace seals. 16.3 Check if bolts are tighten with the correct torque. Clean the surface and reseal with Loctite 518. 16.4 Replace bracket. 16.5 Reseal and tighten bolts with prescribed torque. 16.6 Tighten or replace. 16.7 Tighten dipstick or replace o-ring dipstick. 16.8 Tighten filter or replace o-ring filter 16.9 Remove excessive fluid with commercial suction pump. 16.10 Remove paint or dirt from breather. 16.11 Replace aluminium washers.



Symptom	Possible cause	Remedy
17. High oil temperature.	17.1 Excessive fluid in transmission. 17.2 Oil cooler is dirty. 17.3 No water in circuit. 17.4 Undersized cooler. 17.5 Clutch is slipping. 17.6 Excessive friction of the reverse clutch. 17.7 Possible bypass in the cooling circuit.	17.1 Remove excessive fluid with commercial suction pump. 17.2 Replace the cooler and check the water circuit. 17.3 Check the cooling circuit. 17.4 Replace the cooler with a proper one 17.5 Refer to 18. 17.6 Check the clutch play and the correct position of the piston. 17.7 Reduce the bypass.
18. Slipping clutch.	18.1 Low pressure. 18.2 Fluid level in transmission is low. 18.3 Shift lever not properly adjusted. 18.4 Trolling lever not in the detent position. 18.5 Wear on clutch discs. 18.6 Piston rings in clutch are faulty. 18.7 Inadmissible fluid used. 18.8 Water in the fluid. 18.9 Piston rings on input shaft are faulty.	18.1 Refer to 15. 18.2 Refill with fluid. 18.3 Regulate at the end of the way. 18.4 Adjust the lever at the detent position. 18.5 Disassemble transmission, replace clutch discs. 18.6 Disassemble transmission, replace piston rings. 18.7 Drain fluid, refill with prescribed fluid. 18.8 Repair leakage at cooler or replace cooler. Change transmission fluid. 18.9 Remove control block and replace piston rings.
19. Noise.	- hydraulic 19.1 Oil filter is dirty. 19.2 Fluid level in transmission is low. 19.3 Oil suction hose not properly adjusted. 19.4 Defective cover filter : air suction. - at idle speed 19.5 Coupling. - under load 19.6 Wrong shimming. 19.7 Defective gears.	19.1 Replace oil filter. 19.2 Refill with fluid. 19.3 Replace the seal and adjust correctly the suction hose. 19.4 Replace cover filter. 19.5 Replace. 19.6 Re-shim. 19.7 Replace defective gears.
20. Engagement not possible.	20.1 Fluid level in transmission is low. 20.2 Fine filter is dirty. 20.3 Incorrect shift lever position. 20.4 Coupling is damaged. 20.5 Control block. 20.6 Shifting lever is loose. 20.7 Low pressure.	20.1 Refill with fluid. 20.2 Replace fine filter. 20.3 Regulate at the end of the way. 20.4 Replace coupling. 20.5 Replace control block. 20.6 Tighten clamping bolt on shifting lever. 20.7 Refer to 15.
21. Slow engagement.	21.1 Fluid level in transmission is low. 21.2 Shift lever. 21.3 Regulate.	21.1 Refill with fluid. 21.2 Low pressure. 21.3 Refer to 15.
22. Hard shifting.	22.1 Shift lever. 22.2 Control block is dirty.	22.1 Regulate. 22.2 Disassemble the control valve and clean.



Symptom	Possible cause	Remedy
23. Transmission is dragging in neutral.	23.1 Warped discs due to overheating. 23.2 Needle bearings on input shaft are faulty. 23.3 Intermediate gear moved from the shaft and touching the clutch drum. 23.4 Discs of the reverse clutch radially broken due to torsional vibration.	23.1 Replace discs, replace any other faulty parts. 23.2 Disassemble transmission, replace needle bearings. 23.3 Replace the intermediate gear. 23.4 Replace the discs and change the damper with a proper one.
24. Water in the oil.	24.1 Fluid cooler faulty. 24.2 Water in bilge.	24.1 Repair leakage at cooler or replace cooler. 24.2 Remove water from the bilge and check the oil seal.

10. AUTOMATIC TRANSMISSION FLUID

MANUFACTURER	PRODUCT	MANUFACTURER	PRODUCT
ADDINOL MINERALÖL GMBH, KRUMPA/D	<ul style="list-style-type: none"> • ADDINOL ATF D IID • ADDINOL ATF D III 	ENGEN PETROLEUM, CAPE TOWN/ZA	<ul style="list-style-type: none"> • ENGEN ATF 22D
AGIP PETROLI SPA, ROM/I	<ul style="list-style-type: none"> • AGIP ATF II D • AGIP ATF D 309 • AGIP ATF PLUS • AGIP DEXRON III 	ERTOIL SA, MADRID/E	<ul style="list-style-type: none"> • TRANSMISIONES AUTOMATICAS D2
AGIP SCHMIERTECHNIK, WÜRZBURG/D	<ul style="list-style-type: none"> • AUTOL GETRIEBEÖL ATF-D • AUTOL GETRIEBEÖL ATF III D 	ESSO AG, HAMBURG/D	<ul style="list-style-type: none"> • ESSO ATF D (21611) • ESSO ATF F-30320 • ESSO ATF D (21065)
ARAL LUBRICANTS GMBH, BOCHUM/D	<ul style="list-style-type: none"> • ARAL GETRIEBEÖL ATF 22 • ARAL GETR.ÖL ATF 55 F-30589 	FIAT LUBRIFICANTI, VILLASTELLONE/I	<ul style="list-style-type: none"> • TUTELA GI/A
AVIA MINERALÖL-AG, MÜNCHEN/D	<ul style="list-style-type: none"> • AVIA FLUID ATF 86 	FINA EUROPE SA, BRÜSSEL/B	<ul style="list-style-type: none"> • FINAMATIC II-D
BLASER SWISSLUBE, HASLE-RÜEGSAU/CH	<ul style="list-style-type: none"> • BLASOL 229 	FUCHS LUBRICANTS (UK), DERBY/GB	<ul style="list-style-type: none"> • SILKTRAN MP-ATF • SILKTRAN PSV ATF
BP OIL DEUTSCHLAND, HAMBURG/D	<ul style="list-style-type: none"> • FRONTOL UNIVERSAL-ATF 100 	FUCHS MINERALÖLWERKE, MANNHEIM/D	<ul style="list-style-type: none"> • TITAN ATF 4000
BP OIL INTERNATIONAL, LONDON/GB	<ul style="list-style-type: none"> • AUTRAN DX II • AUTRAN MBX • AUTRAN DX III (F-30370) • AUTRAN DX III (F-30381) 	GINOUVES GEORGES SA, LA FARLEDE/F	<ul style="list-style-type: none"> • YORK LT 785
BUCHER + CIE AG, LANGENTHAL/CH	<ul style="list-style-type: none"> • MOTOREX ATF SUPER D-22656 • MOTOREX ATF DEXRON III MC 	GULF OIL (GB) LTD, CHELTENHAM/GB	<ul style="list-style-type: none"> • UNIFLUID • ATF 2
CALPAM GMBH, ASCHAFFENBURG/D	<ul style="list-style-type: none"> • PAMATIC FLUID 289 • CALPAMATIC FLUID III F 	HANDELSMIJ NOVIOL B.V., NIJMEGEN/NL	<ul style="list-style-type: none"> • KENDALL ATF DEXRON IID
CALTEX PETROLEUM CORP., LONDON/GB	<ul style="list-style-type: none"> • CALTEX ATF-HDA • CALTEX ATF-HDM • CALTEX TEXAMATIC 1278 • CALTEX TEXAMATIC 7045 • CALTEX TEXAMATIC 1205A 	HOMBERG GMBH + CO KG, WUPPERTAL/D	<ul style="list-style-type: none"> • HOMBERG-GETRIEBE-FLUID D
CASTROL LTD, SWINDON/GB	<ul style="list-style-type: none"> • CASTROL TQ-D (22765) • CASTROL TQ DEXRON III F-30520 • CASTROL TRANSMAX S (F-30319) • CASTROL TRANSMAX T (F-30359) • CASTROL TQ-D (21289) • CASTROL ATF 21293 	IGOL FRANCE, PARIS/F	<ul style="list-style-type: none"> • IGOL ATF 420
CEPSA, MADRID/E	<ul style="list-style-type: none"> • CEPSA ATF-70 	INA RAFINERIJA ZAGREB/CROATIA	<ul style="list-style-type: none"> • INA-ATF SUPER
CHEVRON PRODUCTS CO., RICHMOND/USA	<ul style="list-style-type: none"> • CHEVRON ATF F-30108 	ITALIANA PETROLI, GENOVA/I	<ul style="list-style-type: none"> • TRANSMISSION FLUID DX
CITGO PETROLEUM CORP., TULSA/USA	<ul style="list-style-type: none"> • CITGO ATF DEXRON III F-30167 	JAPAN ENERGY CORP., TOKYO/JAPAN	<ul style="list-style-type: none"> • JOMO ATF K
C.J.DIEDERICH SÖHNE, WUPPERTAL/D	<ul style="list-style-type: none"> • CIDISOL-HYDR.-FLUID DEXRON IID 	KÄPPLER K., STUTTGART/D	<ul style="list-style-type: none"> • SELECTOL FLUID GETR.ÖL IID 23
DE OLIEBRON B.V., ZWIJNDRECHT/NL	<ul style="list-style-type: none"> • ATF DMM • ATF 289 	KLÖCKNER ENERGIEHANDEL GMBH, KÖLN/D	<ul style="list-style-type: none"> • DEUTZ OEL ATF-D
DEA MINERALÖL AG, HAMBURG/D	<ul style="list-style-type: none"> • DEAMATIC • DEAFLLUID 4011 • DEAFLLUID 3003 	KROON OIL BV, ALMELO/NL	<ul style="list-style-type: none"> • ATF DEXRON IID • ALMIROL ATF
DEUTSCHE SHELL AG, HAMBURG/D	<ul style="list-style-type: none"> • MAC ATF D-21666 	KUWAIT PETROLEUM, HOOGVLIET/NL	<ul style="list-style-type: none"> • Q8 AUTO 15 • Q8 AUTO 14 (IID-21677) • Q8 AUTO 14 (IID) • Q8 AUTO 14 (IID-21883)
DUCKHAMS OIL, BROMLEY/GB	<ul style="list-style-type: none"> • UNIMATIC 	LEPRINCE + SIVEKE GMBH, HERFORD/D	<ul style="list-style-type: none"> • LEPRINXOL FLUID CN
ELF LUBRIFIANTS, PARIS/F	<ul style="list-style-type: none"> • TRANSANTAR DF2 • ANTAR 22329 • ELFMATIC G2 22329 • HUILE RENAULT DIESEL • STARMATIC 	LIQUI MOLY / MEGUIN, ULM/D	<ul style="list-style-type: none"> • ATF IIE • MEGOL ATF IID
ELFMATIC G3	<ul style="list-style-type: none"> • TRANSANTAR DF3 	LUBRICATION ENGIN., FORT WORTH/USA	<ul style="list-style-type: none"> • AUTOMATIC TRANSMISSION FLUID
ELLER-MONTAN-COMP., DUISBURG/D	<ul style="list-style-type: none"> • ELLMO-AUTOMATIK-FLUID 22233 	MAURAN SA, ODARS/F	<ul style="list-style-type: none"> • INTER OIL INTER MATIC ATF D2
		MIN.ÖL-RAFFIN. DOLLBERGEN, UETZE/D	<ul style="list-style-type: none"> • PENNASOL FLUID-GETR.ÖL TYP PCN
		MOBIL OIL, WEDEL/D	<ul style="list-style-type: none"> • MOBIL ATF 220 D20104 / D21685 • MOBIL ATF F-30107 • MOBIL ATF 220 D21412 / D22187
		MOBIL SEKIYU KABUS. KAISHA, TOKYO/J	<ul style="list-style-type: none"> • MOBIL ATF 220Y (D-21412)
		MOL HUNGARIAN OIL, KOMARON/H	<ul style="list-style-type: none"> • CARRIER ATF
		MORRIS LUBRICANTS, SHREWSBURY/GB	<ul style="list-style-type: none"> • LIQUIMATIC DII
		NAFTEC, ALGIER/DZ	<ul style="list-style-type: none"> • TASSILIA



MANUFACTURER	PRODUCT
NANHAI SUPERIOR LUB-OIL, CHINA	• NANHAI ATF (D2)
NIS-RAFINERIJA NAFTE BEOGRAD/YU	• GALAX MATIC DAC
OEST G. MIN.ÖLWERK, FREUDENSTADT/D	• ATF T 4011
OMEX PETROLEUM PTY, BELLEVUE/AUS	• OMEX ATF DEXRON II
OMV AG, SCHWECHAT/A	• OMV ATF D II (D22427) • OMV ATF III (F-30580)
OPTIMOL ÖLWERKE, HAMBURG/D	• OPTIMOL ATF T 4011
OSWALD KLUTH, BARGFELD-STEGEN/D	• UNIVERSAL ATF-D
PAKELO MOTOR OIL, SAN BONIFACIO/I	• MULTIPURPOSE TRANSM. FLUID IID
PANOLIN AG, MADETSWIL/CH	• PANOLIN ATF MULTI 21996 • PANOLIN ATF DEXRON III
PARS OIL CO., TEHRAN/IR	• PARS ENTEGHAL-E AUTOMATIC OIL
PAZ LUBRICANTS & CHEMICALS, HAIFA/IL	• PAZBO EZF
PENNZOIL PRODUCT COMP., HOUSTON/USA	• PENNZOIL ATF F-30110
PETRO-CANADA, MISSISSAUGA/CDN	• DEXRON III/MERC.ATF (F-30395)
PETROL OFISI A.S., BAKANLIKAR/TR	• PETROL OFISI ATF II
PETROLEX, KWIDZYN/PL	• VECO MATIC IID
PRINZ-SCHULTE, FRECHEN/D	• AERO-LINE ATF-2 • AERO-LINE ATF-D
REPSOL DISTRIBUCION SA, MADRID/E	• REPSOL MATIC ATF
S.A.E.L, ALCOBENDAS/E	• GULF ATF DII D-22233
SASOL OIL, RANDBURG/ZA	• SASOL ATF DXII
SCHMIERSTOFFRAFFINERIE SALZBERGEN/D	• WINTERSHALL ATF D
SHELL ASEOL AG, BERN/CH	• ASEOL ATF DB UNIVERSAL
SHELL INTERNATIONAL, LONDON/GB	• SHELL DONAX TA (D-21666) • SHELL DONAX TG (F-30358)
SLOVNAFT JS CO, BRATISLAVA/SLO	• MADIT AUTOMATIC
SONOL ISRAEL LTD, HAIFA/IL	• DEXRON 2 D

MANUFACTURER	PRODUCT
SOPROGRASA SA, MADRID/E	• SOPRAL 164
STATOIL STAVANGER/N	• TRANSWAY DX III (F-30373) • TRANSWAY DX II
STL TECNOL, ESCALQUENS/F	• TECNOL TECMATIC D2
SUN OIL COMPANY, AARTSELAAR/B	• SUNAMATIC 149 • SUNAMATIC 153
SUOMEN PETROOLI OY, HAMINA/SF	• TEBOIL FLUID E (F-30301) • TEBOIL FLUID D
SVENSKA STATOIL AB, NYNÄSHAMN/S	• TRANSWAY DX III (F-30373)
TAMOIL LUBES, GENEVA/CH	• TAMOIL ATF II D
TEXACO LUBRICANTS COMP., BEACON/USA	• ATF MERCON / DEXRON III • TEXAMATIC 7045 • TEXAMATIC 4261 • TEXAMATIC 7080 • TEXTRAN PSM • TEXAMATIC 4011 • TEXAMATIC 4291 • TEXAMATIC 9226
TEXACO SERVICES LTD, BRÜSSEL/B	• TEXAMATIC 7045 • TEXAMATIC 4261 • TEXAMATIC 7080 • TEXTRAN PSM • TEXAMATIC 4011 • TEXAMATIC 4291 • TEXAMATIC 9226
TOTAL RAFFINAGE DISTR., PARIS/F	• TOTAL FLUIDE ATX • TOTAL FLUIDE IID • TOTAL FLUIDE AT 42
TOTAL SOUTH AFRICA, JOHANNESBURG/ZA	• TOTAL FLUIDE ATD
TURBOTANK BÖSCHE BÖDEKER, BREMEN/D	• TURBO UNIV. ATF MERCON 4011
UFANEFTECHIM REFINERY, UFA/RUS	• UFALUB ATF
UNIL DEUTSCHLAND GMBH, BREMEN/D	• UNIL MATIC CN T 4011
VALVOLINE INC., LEXINGTON/USA	• VALVOLINE MULTI-PURPOSE ATF
VALVOLINE INTERNAT., DORDRECHT/NL	• VALVOLINE ATF TYPE D
VEBA OEL AG, GELSENKIRCHEN/D	• MOVARA ATF-GETRIEBEÖL DIID
VEEDOL INTERNATIONAL, SWINDON/GB	• VEEDOL ATF-M (22764) • VEEDOL ATF DEXRON III F-30521 • VEEDOL UNITRANS S PLUS
YACCO SA, ST PIERRE-LES-ELBEUF/F	• YACCO ATF D
ZELLER + GMELIN GMBH&CO, EISLINGEN/D	• DIVINOL FLUID 666



11. SPARE PARTS LIST ZF63 IV - ZF80 IV - ZF80-1 IV

Preface

The spare parts list is only valid for the type and versions of transmission, as shown below.

You will find the transmission type and version on your transmission name plate.

If the type and version indicated differs from that printed in this Manual, the relative Spare Parts List should be ordered from ZF HURTH MARINE.

The indicated dimensions and standards are as such not enough for ordering parts.

When ordering parts, please state:

- Transmission type
- Serial number
- Item no.
- Part name
- Identification no.
- quantity of parts required.

The spare parts list is referring to the following versions:

ZF 63 IV	versions 14 (1.29 R); 15 (1.56 R); 16 (2.00 R); 17 (2.48 R); versions 001 (1.29 R); 002 (1.56 R); 003 (2.00 R); 004 (2.48 R); versions 012 (1.29 R); 013 (1.56 R); 014 (2.00 R); 015 (2.48 R);
ZF 80 IV	versions 04 (1.21 R); 05 (1.40 R); 01 (1.64 R); 02 (2.01 R); 03 (2.49 R); versions 001 (1.21 R); 002 (1.40 R); 003 (1.64 R); 004 (2.01 R); 005 (2.49 R);
ZF 80-1 IV	versions 007 (1.21 R); 008 (1.40 R); 006 (1.64 R); 009 (2.01 R); 010 (2.49 R);

Name plate

The name plate is mounted to the transmission

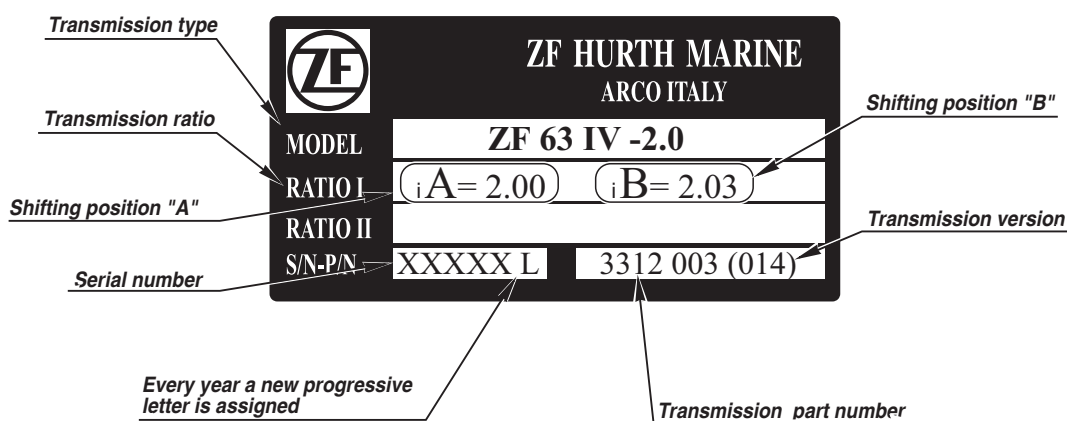

ZF 63 IV

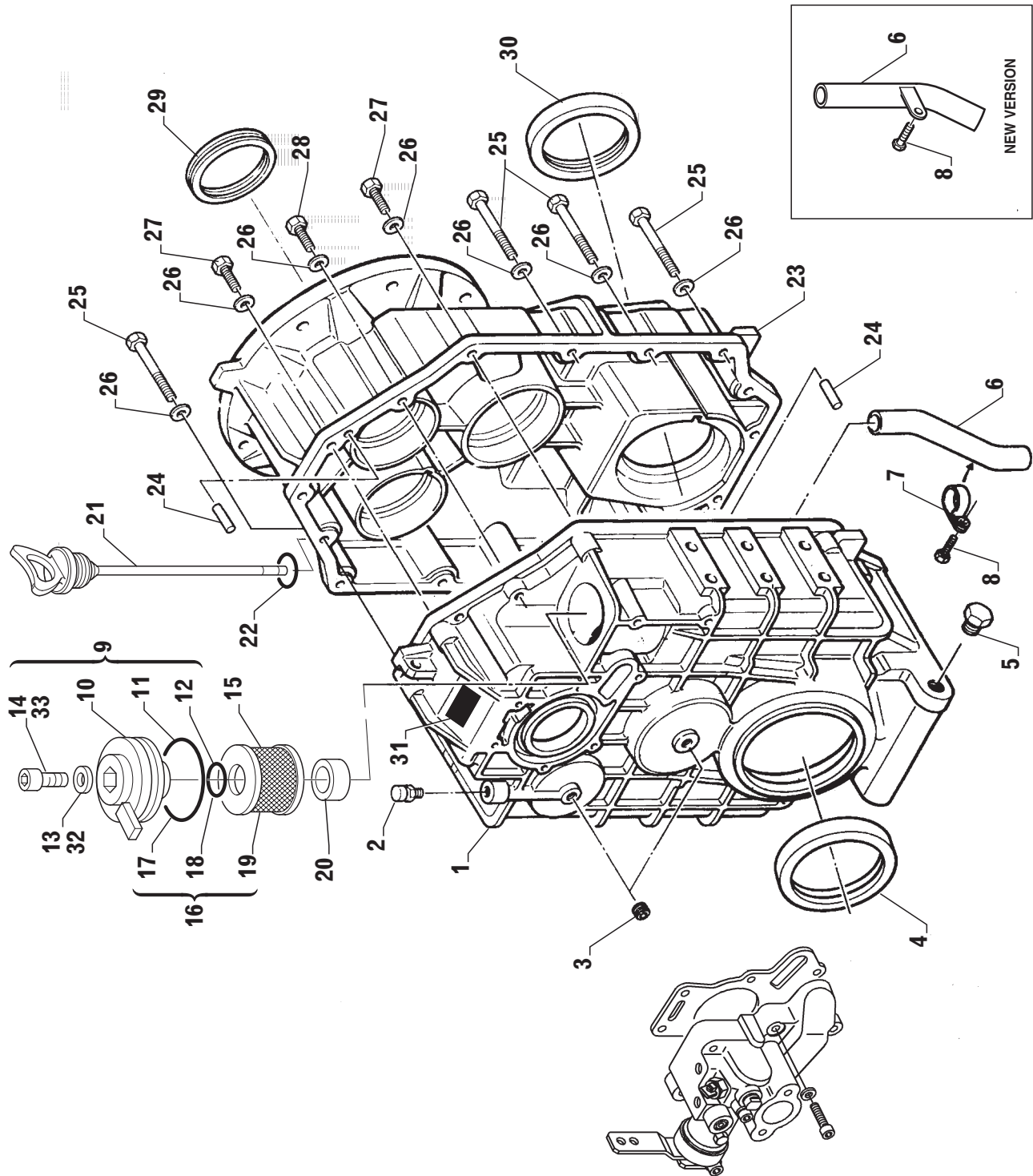



Pos.	Part number	Old P/N	Descrizione	Description	Q.tà Q.ty	Note
1	3312 301 025	469246	Scatola	Housing	1	
2	3311 301 002	442369	Valvola di sfiato	Breather valve	1	
	3312 301 035		Valvola di sfiato Hunger	Hunger breather valve	1	Only ratio I = 1.56
3	0636 301 041	442373	Tappo	Plug	2	
4	0634 319 133	444070	Paraolio uscita	Output shaft seal	1	
●	0734 319 742		Paraolio uscita	Output shaft seal	1	Only ratio I = 1.56 (also Indmar version)
5	3312 301 017	469691	Tappo	Plug	1	
6	3312 301 026	456665	Tubo aspirazione	Suction pipe	1	
	3312 301 034		Tubo aspirazione con supporto	Suction pipe with support	1	
7	0632 311 397	473352	Ritegno	Retainer support	1	
8	0636 101 439	102867	Vite T.E.	Hex head screw	1	
9	3312 101 003	500484	Coperchio filtro completo	Filter cover, assy.	1	
10	☆		. Coperchio filtro	. Filter cover	1	
11	0634 304 688	442731	. Guarnizione OR	. O-Ring	1	
12	0634 306 204	105542	. Guarnizione OR	. O-Ring	1	
13	0630 001 085	167010	. Rosetta	. Washer	1	
14	0636 101 475	320202	. Vite M8x30	. Screw M8x30	1	
15	3312 301 007	438637	Filtro olio	Oil filter	1	* old part number
16	3312 199 031	463772	Filtro olio completo	Oil filter, assy	1	
17	0634 304 688	442731	. Guarnizione OR	. O-Ring	1	
18	0634 306 204	105542	. Guarnizione OR	. O-Ring	1	
19	3312 301 037		. Filtro olio	. Oil filter	1	* new part number
20	3312 301 008	439653	Guarnizione	Gasket	1	
▼21	978.31.701.02	465996	Asta livello olio	Oil dipstick	1	
△	3312 201 003	500991	Asta livello olio + OR	Oil dipstick + OR	1	
22	0634 304 405	501211	. Guarnizione OR	. O-Ring	1	
23	3312 301 024	469243	Coperchio	Cover (housing)	1	
24	0631 315 520	335817	Spina	Locator pin	2	
25	0636 010 550	442374	Vite T.E.	Hex head screw	4	
26	0630 302 091	442371	Rosetta	Washer	16	
27	0636 015 227	442375	Vite T.E.	Hex head screw	11	
28	0636 015 386	452512	Vite T.E.	Hex head screw	1	
29	3312 301 030	413883	Paraolio entrata	Input shaft seal	1	
30	0634 319 134	444071	Paraolio uscita	Output shaft seal	1	
●	0734 319 741		Paraolio uscita	Output shaft seal	1	Only ratio I = 1.56 (also Indmar version)
31	3312 301 001		Targhetta di identificazione	Name plate	1	
32	0630 001 085	167010	Rosetta	Washer	1	
33	0636 101 475	320202	Vite M8x30	Screw M8x30	1	

▼ Fino a matricola 20754F - Up to s/n 20754F

△ Da matricola 20755F - From s/n 20755F

● Da matricola 19098M - From s/n 19098M

* Fornito solamente incluso nel Kit filtro olio p/n 3312 199 031
Supplied only included in the oil filter Kit p/n 3312 199 031

ZF 80 IV - ZF 80-1 IV

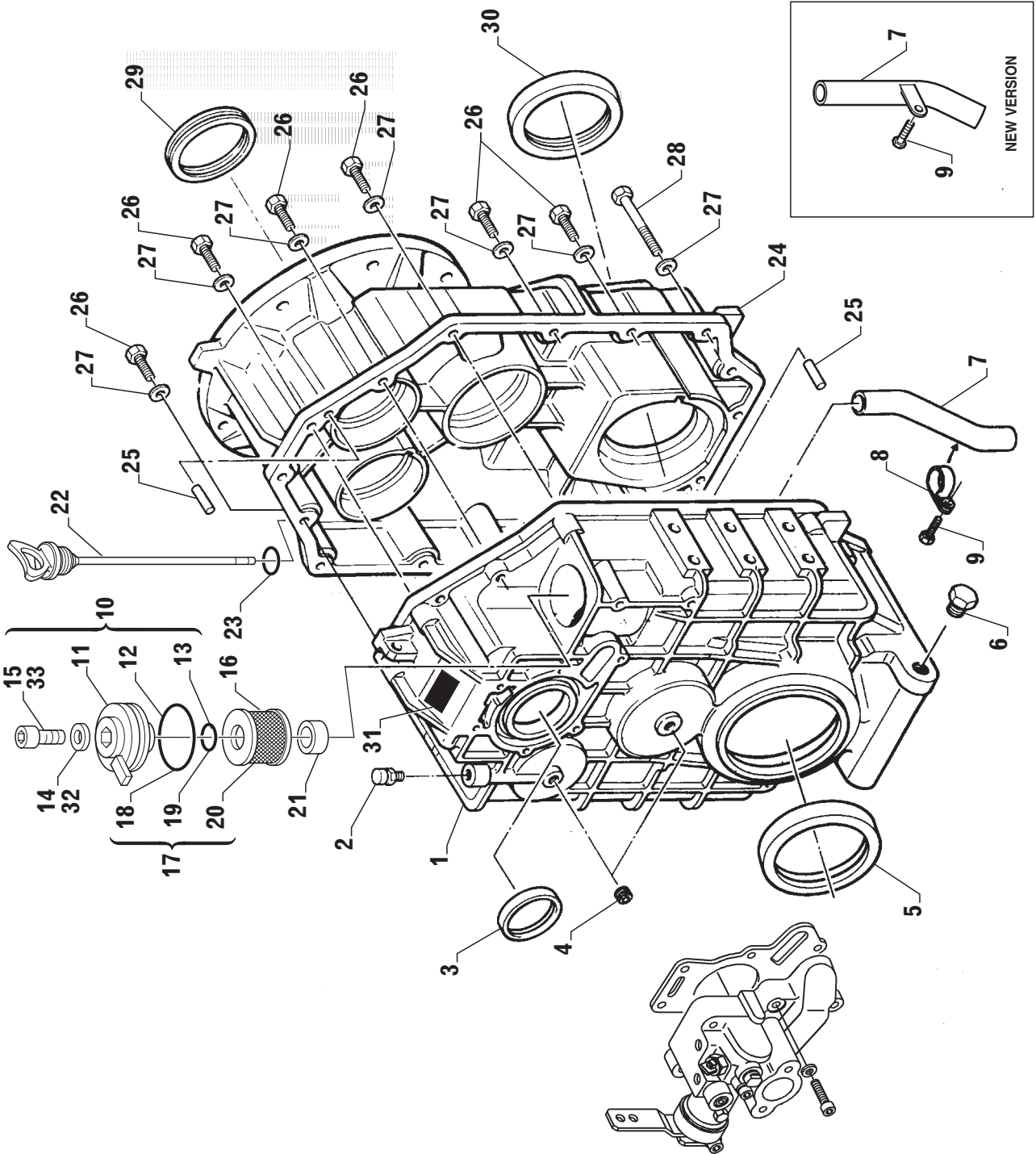



Pos.	Part number	Old P/N	Descrizione	Description	Q.tà Q.ty	Note
1	3313 301 017	489135	Scatola	Housing	1	
2	3311 301 002	442369	Valvola di sfiato	Breather valve	1	
3	3313 301 014	462997	Anello centratore	Centering ring	1	
4	0636 301 041	442373	Tappo	Plug	2	
5	0634 309 631	105113	Paraolio uscita	Output shaft seal	1	
6	3312 301 017	469691	Tappo	Plug	1	
7	3313 301 018	480698	Tubo aspirazione	Suction pipe	1	
	3313 301 024		Tubo aspirazione con supporto	Suction pipe with support	1	
8	0632 311 398	479439	Fascetta	Suction pipe clamp	1	
9	0636 101 411	102879	Vite T.E. (fascetta tubo aspirazione)	Hex head screw (suction pipe clamp)	1	
10	3312 101 003	500484	Coperchio filtro completo	Filter cover, assy.	1	
11	☆		. Coperchio filtro	. Filter cover	1	
12	0634 304 688	442731	. Guarnizione OR	. O-Ring	1	
13	0634 306 204	105542	. Guarnizione OR	. O-Ring	1	
14	0630 001 085	167010	. Rosetta	. Washer	1	
15	0636 101 475	320202	. Vite M8x30	. Screw M8x30	1	
16	3312 301 007	438637	Filtro olio	Oil filter	1	* old part number
17	3312 199 031	463772	Filtro olio completo	Oil filter, assy	1	
18	0634 304 688	442731	. Guarnizione OR	. O-Ring	1	
19	0634 306 204	105542	. Guarnizione OR	. O-Ring	1	
20	3312 301 037		. Filtro olio	. Oil filter	1	* new part number
21	3312 301 008	439653	Guarnizione	Gasket	1	
▼22	978.61.701.01	480700	Asta livello olio	Oil dipstick	1	
△	3313 201 002	500990	Asta livello olio + OR	Oil dipstick + OR	1	
23	0634 304 405	501211	. Guarnizione OR	. O-Ring	1	
24	3313 301 016	480425	Coperchio	Cover (housing)	1	
25	0631 315 520	335817	Spina	Locator pin	2	
26	0636 015 227	442375	Vite T.E.	Hex head screw	15	
27	0630 302 091	442371	Rosetta	Washer	16	
28	0636 010 463	315548	Vite T.E.	Hex head screw	1	
29	3312 301 030	413883	Paraolio entrata	Input shaft seal	1	
30	0634 309 619	480762	Paraolio uscita	Output shaft seal	1	
31	3312 301 001		Targhetta di identificazione	Name plate	1	
32	0630 001 085	167010	Rosetta	Washer	1	
33	0636 101 475	320202	Vite M8x30	Screw M8x30	1	

▼ Fino a matricola 34303E - Up to s/n 34303E

△ Da matricola 34304E - From s/n 34304E

* Fornito solamente incluso nel Kit filtro olio p/n 3312 199 031
Supplied only included in the oil filter Kit p/n 3312 199 031

ZF 63 IV

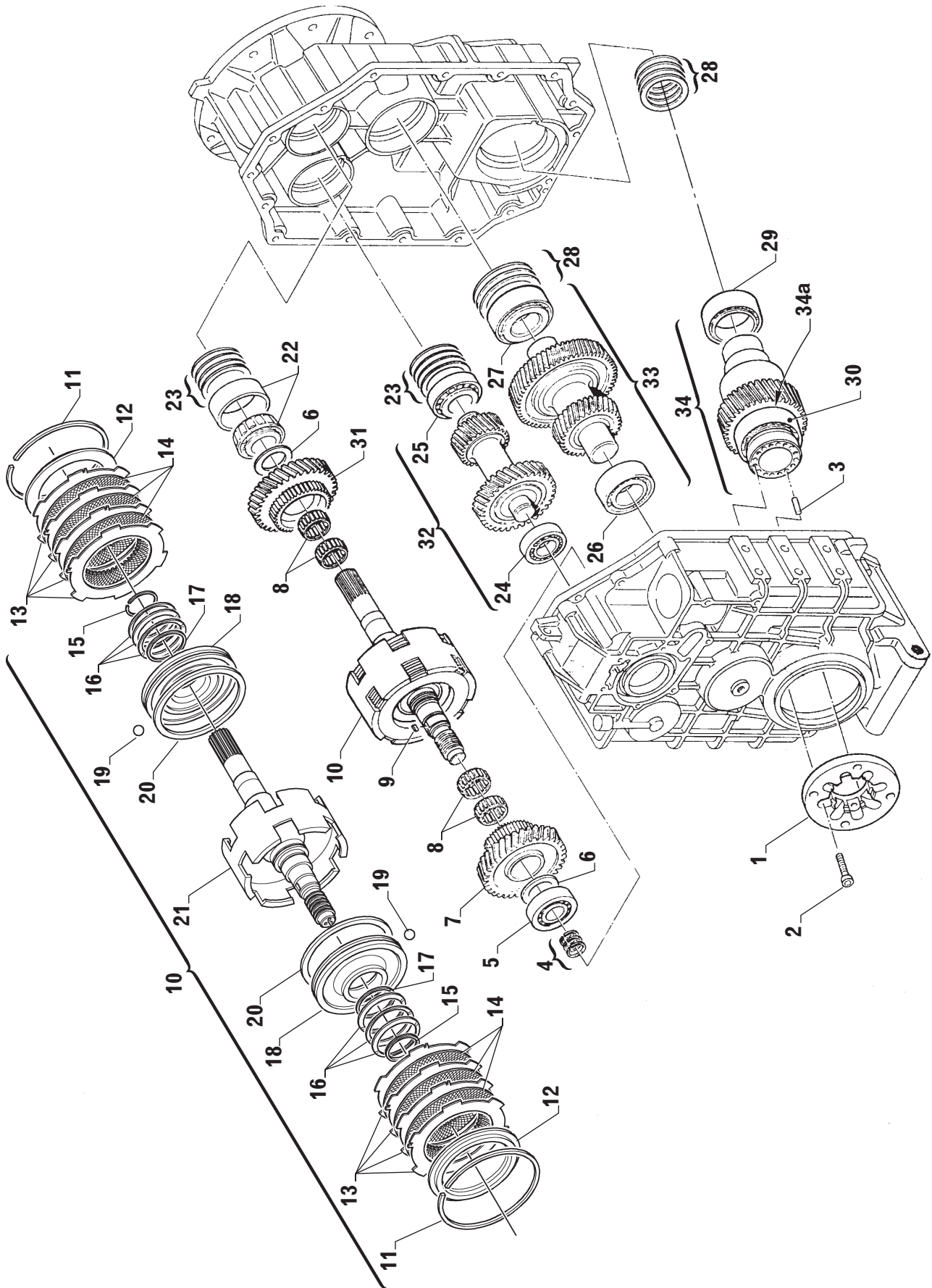



Pos.	Part number	Old P/N	Descrizione	Description	Q.tà Q.ty	Note
1	3312 304 015	465110	Flangia	Flange	1	
2	0636 101 030	446131	Vite	Screw	8	
3	0631 313 008	104684	Spina	Locator pin	4	
4	3312 302 041	447038	Anello di tenuta	Piston ring	3	
5	0635 501 940	500365	Cuscinetto a rulli conici	Tapered roller bearing	1	
6	3312 302 004	454406	Rasamento	Butting ring	2	
7	3312 302 006	488955	Ingranaggio Z3 = 49	Reverse gear Z3 = 49	1	
8	3312 302 040	441438	Cuscinetto a rullini	Needle bearing	4	
9	0631 501 062	437956	Chiavetta	Key	1	
10	3312 199 051		Albero di ingresso completo	Input shaft, assy.	1	
11	0630 513 066	455788	. Anello elastico	. Snap ring	2	
12	3312 302 012	455789	. Disco finale	. End disc	2	
13	3312 302 008	455787	. Disco frizione esterno	. Outer clutch disc	10	
14	3312 302 009	455786	. Disco frizione interno	. Inner clutch disc	8	
15	0630 501 038	500076	. Anello di ritegno	. Retainer ring	2	
16	3312 302 015	500148	. Molla a tazza	. Cup spring	6	
	3312 302 038		. Molla a tazza	. Cup spring	6	From s/n 18483L
17	0634 402 178	500066	. Anello interno	. Inner clutch piston ring	2	
18	3312 302 014	500147	. Pistone	. Clutch piston	2	
19	0635 460 006	106690	. Sfera	. Ball	2	
20	0634 402 176	500069	. Anello esterno	. Outer clutch piston ring	2	
21	3312 199 032	500239	. Albero di ingresso + cilindro frizione	. Input shaft and clutch housing	1	
22	0635 501 937	447754	Cuscinetto a rulli conici	Tapered roller bearing	1	
23	3312 302 023	277213	Spessore 0,1 mm	Shim 0.1 mm	2	
	3312 302 024	277214	Spessore 0,15 mm	Shim 0.15 mm	2	
	3312 302 025	277215	Spessore 0,2 mm	Shim 0.2 mm	2	
	3312 302 026	277216	Spessore 0,5 mm	Shim 0.5 mm	2	
24	0635 501 942	500312	Cuscinetto a rulli conici	Tapered roller bearing	1	
25	0635 501 941	500367	Cuscinetto a rulli conici	Tapered roller bearing	1	
26	0635 501 937	447754	Cuscinetto a rulli conici	Tapered roller bearing	1	
27	0635 372 007	106652	Cuscinetto a rulli conici	Tapered roller bearing	1	
28	3312 304 022	439393	Spessore 0,1 mm	Shim 0.1 mm	2	
	3312 304 023	439394	Spessore 0,15 mm	Shim 0.15 mm	2	
	3312 304 024	439395	Spessore 0,3 mm	Shim 0.3 mm	2	
	3312 304 025	439396	Spessore 0,5 mm	Shim 0.5 mm	2	
29	0635 370 020	159808	Cuscinetto a rulli conici	Tapered roller bearing	1	
30	0635 376 005	446130	Cuscinetto a rulli conici	Tapered roller bearing	1	
Vers. 14,001,012 (Rapporto I = 1,29)				Vers. 14,001,012 (Ratio I = 1.29)		
31	3312 302 019	500856	Ingranaggio Z1 = 39	Forward gear Z1 = 39	1	
32	3312 199 037	470060	Albero intermedio Z4 = 45, Z5 = 36	Intermediate shaft Z4 = 45, Z5 = 36	1	*
33	3312 199 038	470059	Albero intermedio Z2 = 49, Z6 = 33	Intermediate shaft Z2 = 49, Z6 = 33	1	*
34	3312 199 039	470062	Albero di uscita Z7 = 34	Output shaft Z7 = 34	1	*
34a	3312 304 016	466275	. Distanziale	. Spacer	1	
Vers. 15,002,013 (Rapporto I = 1,56)				Vers. 15,002,013 (Ratio I = 1.56)		
31	3312 202 008	439253	Ingranaggio Z1 = 35	Forward gear Z1 = 35	1	
32	3312 199 040	470065	Albero intermedio Z4 = 45, Z5 = 32	Intermediate shaft Z4 = 45, Z5 = 32	1	*
33	3312 199 041	470064	Albero intermedio Z2 = 53, Z6 = 33	Intermediate shaft Z2 = 53, Z6 = 33	1	*
34	3312 199 039	470062	Albero di uscita Z7 = 34	Output shaft Z7 = 34	1	*
34a	3312 304 016	466275	. Distanziale	. Spacer	1	
Vers. 16,003,014 (Rapporto I = 2,00)				Vers. 16,003,014 (Ratio I = 2.00)		
31	3312 202 009	439254	Ingranaggio Z1 = 30	Forward gear Z1 = 30	1	
32	3312 199 042	470068	Albero intermedio Z4 = 45, Z5 = 27	Intermediate shaft Z4 = 45, Z5 = 27	1	*
33	3312 199 043	470067	Albero intermedio Z2 = 58, Z6 = 33	Intermediate shaft Z2 = 58, Z6 = 33	1	*
34	3312 199 039	470062	Albero di uscita Z7 = 34	Output shaft Z7 = 34	1	*
34a	3312 304 016	466275	. Distanziale	. Spacer	1	
Vers. 17,004,015 (Rapporto I = 2,48)				Vers. 17,004,015 (Ratio I = 2.48)		
31	3312 202 009	439254	Ingranaggio Z1 = 30	Forward gear Z1 = 30	1	
32	3312 199 042	470068	Albero intermedio Z4 = 45, Z5 = 27	Intermediate shaft Z4 = 45, Z5 = 27	1	*
33	3312 199 044	470071	Albero intermedio Z2 = 58, Z6 = 32	Intermediate shaft Z2 = 58, Z6 = 32	1	*
34	3312 199 045	470070	Albero di uscita Z7 = 41	Output shaft Z7 = 41	1	*

* Cuscinetti a rulli conici già assemblati - *Tapered roller bearings already assembled*

ZF 80 IV - ZF 80-1 IV

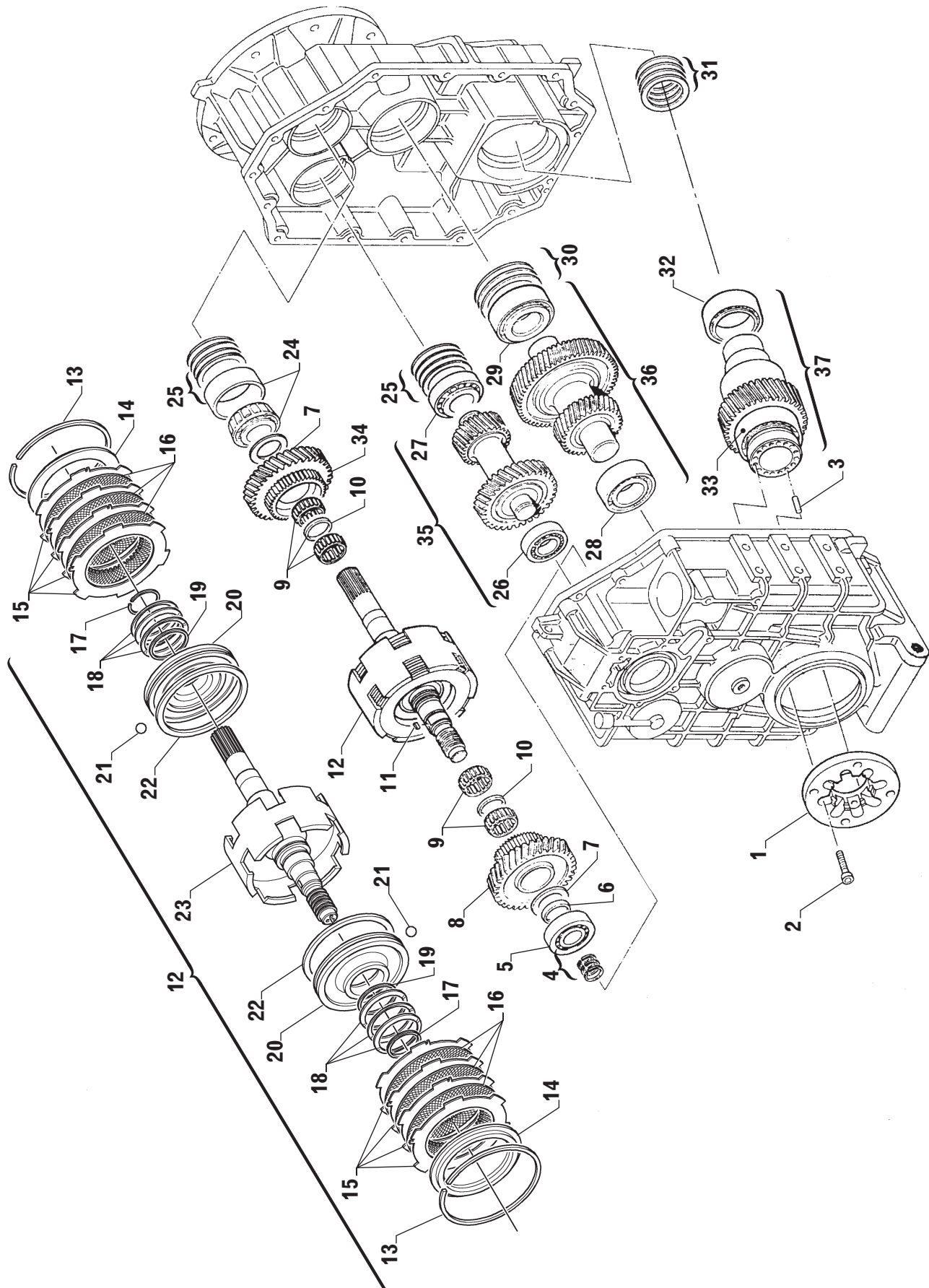



Pos.	Part number	Old P/N	Descrizione	Description	Q.tà Q.ty	Note
1	3313 304 019	480566	Flangia	Flange	1	
2	0636 101 072	312590	Vite	Screw	8	
3	0631 313 056	104661	Spina	Locator pin	4	
4	3312 302 041	447038	Anello di tenuta	Piston ring	3	
5	0635 501 937	447754	Cuscinetto a rulli conici	Tapered roller bearing	1	
6	3313 302 037	488628	Distanziale	Spacer	1	Ratio I = 1.2 - 1.4
7	3313 302 023	457823	Rasamento	Butting ring	2	
8	3313 302 028	488812	Ingranaggio Z3 = 38	Reverse gear Z3 = 38	1	●
	3313 302 015		Ingranaggio Z3 = 38	Reverse gear Z3 = 38	1	● ●
9	3312 302 040	441438	Cuscinetto a rullini	Needle bearing	4	
10	3313 302 030	439533	Distanziale	Spacer	2	
11	0631 501 062	437956	Chiavetta	Key	1	
12	3313 199 026	486633	Albero di ingresso completo	Input shaft, assy.	1	Ratio I = 1.6 - 2.0 - 2.5
	3313 199 028	500512	Albero di ingresso completo	Input shaft, assy.	1	Ratio I = 1.2 - 1.4
13	0630 513 066	455788	. Anello elastico	. Snap ring	2	
14	3312 302 012	455789	. Disco finale	. End disc	2	
15	3312 302 008	455787	. Disco frizione esterno	. Outer clutch disc	12	
16	3312 302 009	455786	. Disco frizione interno	. Inner clutch disc	10	
17	0630 501 038	500076	. Anello di ritegno	. Retainer ring	2	
18	3312 302 015	500148	. Molla a tazza	. Cup spring	6	
△	3312 302 038		. Molla a tazza	. Cup spring	6	
19	0634 402 178	500066	. Anello interno	. Inner clutch piston ring	2	
20	3312 302 014	500147	. Pistone	. Clutch piston	2	
21	0635 460 006	106690	. Sfera	. Ball	2	
22	0634 402 176	500069	. Anello esterno	. Outer clutch piston ring	2	
23	3313 199 027	500237	. Albero di ingresso + cilindro frizione	. Input shaft and clutch housing	1	Ratio I = 1.6 - 2.0 - 2.5
	3313 199 029	500238	. Albero di ingresso + cilindro frizione	. Input shaft and clutch housing	1	Ratio I = 1.2 - 1.4
24	0635 501 939	500390	Cuscinetto a rulli conici	Tapered roller bearing	1	
25	3313 302 042	439630	Spessore 0,1 mm	Shim 0.1 mm	2	
	3313 302 043	439631	Spessore 0,15 mm	Shim 0.15 mm	2	
	3313 302 044	439632	Spessore 0,2 mm	Shim 0.2 mm	2	
	3313 302 045	439633	Spessore 0,5 mm	Shim 0.5 mm	2	
	3313 302 046	439634	Spessore 1,0 mm	Shim 1.0 mm	2	
26	0635 501 937	447754	Cuscinetto a rulli conici	Tapered roller bearing	1	
27	0635 501 938	333859	Cuscinetto a rulli conici	Tapered roller bearing	1	
28	0635 374 005	229784	Cuscinetto a rulli conici	Tapered roller bearing	1	
29	0635 372 007	106652	Cuscinetto a rulli conici	Tapered roller bearing	1	
30	3312 304 022	439393	Spessore 0,1 mm	Shim 0.1 mm	2	
	3312 304 023	439394	Spessore 0,15 mm	Shim 0.15 mm	2	
	3312 304 024	439395	Spessore 0,3 mm	Shim 0.3 mm	2	
	3312 304 025	439396	Spessore 0,5 mm	Shim 0.5 mm	2	
31	3313 304 031	477560	Spessore 0,1 mm	Shim 0.1 mm	2	
	3313 304 030	477558	Spessore 0,15 mm	Shim 0.15 mm	2	
	3313 304 029	477557	Spessore 0,2 mm	Shim 0.2 mm	2	
	3313 304 028	477551	Spessore 0,5 mm	Shim 0.5 mm	2	
32	0635 370 017	464199	Cuscinetto a rulli conici	Tapered roller bearing	1	
33	0635 373 010	480757	Cuscinetto a rulli conici	Tapered roller bearing	1	

● Solo per ZF 80 IV e ZF 80-1 IV - Rapporto I = 2.49 - Only for ZF 80 IV and ZF 80-1 IV - Ratio I = 2.49

● ● Solo per ZF 80-1 IV - Escluso rapporto I = 2.49 - Only for ZF 80-1 IV - No ratio I = 2.49

△ Da matricola From s/n's: 43513L (ZF 80 IV)
43511L (ZF 80-1 IV)



Pos.	Part number	Old P/N	Descrizione	Description	Q.tà Q.ty	Note
SOLO PER ZF 80 IV - ONLY FOR ZF 80 IV						
Vers. 04,001 (Rapporto I = 1,21)				Vers. 04,001 (Ratio I = 1.21)		
34	3313 302 036	500854	Ingranaggio Z1 = 32	Forward gear Z1 = 32	1	
35	3313 199 041	500515	Albero intermedio Z4 = 39, Z5 = 33	Reversing shaft Z4 = 39, Z5 = 33	1	*
36	3313 199 042	500513	Albero intermedio Z2 = 47, Z6 = 45	Intermediate shaft Z2 = 47, Z6 = 45	1	*
37	3313 199 043	500516	Albero di uscita Z7 = 37	Output shaft Z7 = 37	1	*
Vers. 05,002 (Rapporto I = 1,40)				Vers. 05,002 (Ratio I = 1.40)		
34	3313 302 036	500854	Ingranaggio Z1 = 32	Forward gear Z1 = 32	1	
35	3313 199 041	500515	Albero intermedio Z4 = 39, Z5 = 33	Reversing shaft Z4 = 39, Z5 = 33	1	*
36	3313 199 044	500514	Albero intermedio Z2 = 47, Z6 = 42	Intermediate shaft Z2 = 47, Z6 = 42	1	*
37	3313 199 045	500517	Albero di uscita Z7 = 40	Output shaft Z7 = 40	1	*
Vers. 01,003 (Rapporto I = 1,64)				Vers. 01,003 (Ratio I = 1.64)		
34	3313 302 035	500838	Ingranaggio Z1 = 33	Forward gear Z1 = 33	1	
35	3313 199 046	486677	Albero intermedio Z4 = 39, Z5 = 34	Intermediate shaft Z4 = 39, Z5 = 34	1	*
36	3313 199 047	486665	Albero intermedio Z2 = 46, Z6 = 39	Intermediate shaft Z2 = 46, Z6 = 39	1	*
37	3313 199 048	486680	Albero uscita Z7 = 46	Output shaft Z7 = 46	1	*
Vers. 02,004 (Rapporto I = 2,01)				Vers. 02,004 (Ratio I = 2.01)		
34	3313 202 009	480001	Ingranaggio Z1 = 31	Forward gear Z1 = 31	1	
35	3313 199 049	486678	Albero intermedio Z4 = 39, Z5 = 32	Reversing shaft Z4 = 39, Z5 = 32	1	*
36	3313 199 050	486672	Albero intermedio Z2 = 49, Z6 = 37	Intermediate shaft Z2 = 49, Z6 = 37	1	*
37	3313 199 051	486681	Albero di uscita Z7 = 47	Output shaft Z7 = 47	1	*
Vers. 03,005 (Rapporto I = 2,49)				Vers. 03,005 (Ratio I = 2.49)		
34	3313 202 010	480004	Ingranaggio Z1 = 27	Forward gear Z1 = 27	1	
35	3313 199 052	486679	Albero intermedio Z4 = 39, Z5 = 28	Intermediate shaft Z4 = 39, Z5 = 28	1	*
36	3313 199 053	486676	Albero intermedio Z2 = 53, Z6 = 37	Intermediate shaft Z2 = 53, Z6 = 37	1	*
37	3313 199 051	486681	Albero di uscita Z7 = 47	Output shaft Z7 = 47	1	*
SOLO PER ZF 80-1 IV - ONLY FOR ZF 80-1 IV						
Vers. 006 (Rapporto I = 1,64)				Vers. 006 (Ratio I = 1.64)		
34	3313 302 035	500838	Ingranaggio Z1 = 33	Forward gear Z1 = 33	1	
35	3313 199 061		Albero d'inversione Z4 = 39, Z5 = 34	Reversing shaft Z4 = 39, Z5 = 34	1	*
36	3313 199 062		Albero intermedio Z2 = 46, Z6 = 39	Intermediate shaft Z2 = 46, Z6 = 39	1	*
37	3313 199 063		Albero di uscita Z7 = 46	Output shaft Z7 = 46	1	*
Vers. 007 (Rapporto I = 1,21)				Vers. 007 (Ratio I = 1.21)		
34	3313 302 014		Ingranaggio Z1 = 32	Forward gear Z1 = 32	1	
35	3313 199 054		Albero d'inversione Z4 = 39, Z5 = 33	Reversing shaft Z4 = 39, Z5 = 33	1	*
36	3313 199 055		Albero intermedio Z2 = 47, Z6 = 45	Intermediate shaft Z2 = 47, Z6 = 45	1	*
37	3313 199 043	500516	Albero di uscita Z7 = 37	Output shaft Z7 = 37	1	*
Vers.008 (Rapporto I = 1,40) Vers. 008 (Ratio I = 1.40)						
34	3313 302 014		Ingranaggio Z1 = 32	Forward gear Z1 = 32	1	
35	3313 199 054		Albero d'inversione Z4 = 39, Z5 = 33	Reversing shaft Z4 = 39, Z5 = 33	1	*
36	3313 199 059		Albero intermedio Z2 = 47, Z6 = 42	Intermediate shaft Z2 = 47, Z6 = 42	1	*
37	3313 199 060		Albero di uscita Z7 = 40	Output shaft Z7 = 40	1	*
Vers. 009 (Rapporto I = 2,01)				Vers. 009 (Ratio I = 2.01)		
34	3313 202 009	480001	Ingranaggio Z1 = 31	Forward gear Z1 = 31	1	
35	3313 199 064		Albero d'inversione Z4 = 39, Z5 = 32	Reversing shaft Z4 = 39, Z5 = 32	1	*
36	3313 199 050	486672	Albero intermedio Z2 = 49, Z6 = 37	Intermediate shaft Z2 = 49, Z6 = 37	1	*
37	3313 199 051	486681	Albero di uscita Z7 = 47	Output shaft Z7 = 47	1	*
Vers. 010 (Rapporto I = 2,49)				Vers. 010 (Ratio I = 2.49)		
34	3313 202 011	501698	Ingranaggio Z1 = 27	Forward gear Z1 = 27	1	
35	3313 199 072		Albero d'inversione Z4 = 39, Z5 = 28	Reversing shaft Z4 = 39, Z5 = 28	1	*
36	3313 199 068		Albero intermedio Z2 = 53, Z6 = 37	Intermediate shaft Z2 = 53, Z6 = 37	1	*
37	3313 199 069		Albero di uscita Z7 = 47	Output shaft Z7 = 47	1	*

* Cuscinetti a rulli conici già assemblati - *Tapered roller bearings already assembled*

ZF 63 IV - ZF 80 IV - ZF 80-1 IV

MECHANICAL SELECTOR VALVE

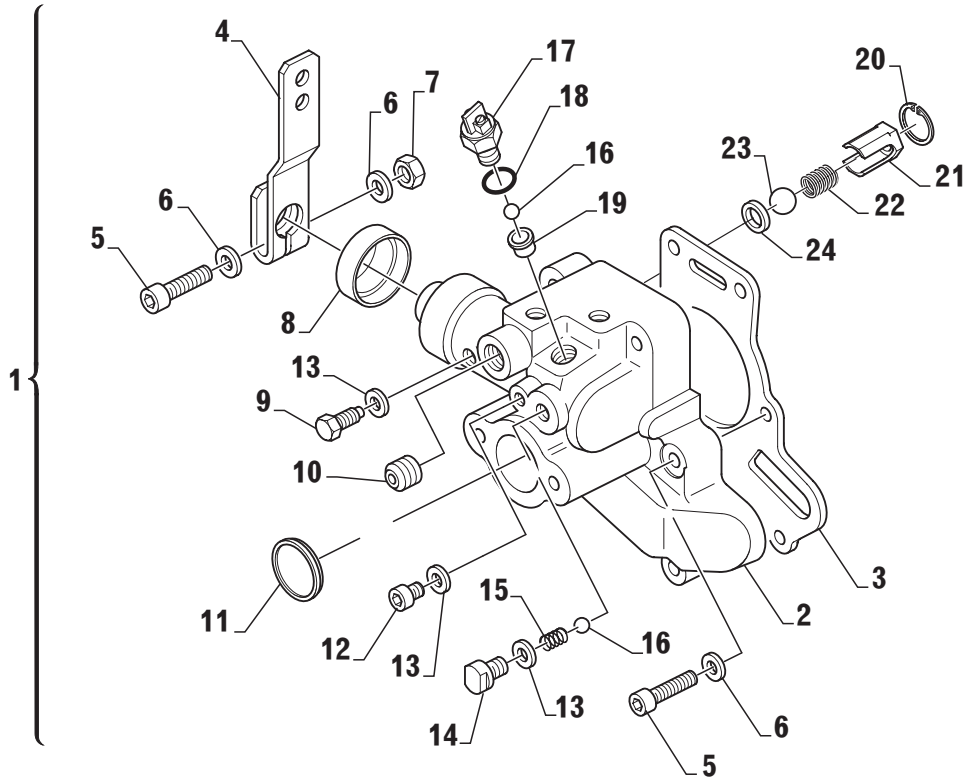



Pos.	Part number	Old P/N	Descrizione	Description	Q.tà Q.ty	Note
1	3312 108 001		Valvola di comando completa 23 bar	Control valve assy. 23 bar	1	
	3312 108 003		Valvola di comando completa 21 bar	High speed control valve assy. 21 bar	1	Only for INDMAR ZF 63 IV
	3313 108 001		Valvola di comando alta velocità 26 bar	High speed control valve assy. 26 bar	1	Only for ZF 80-1 IV
2	☆		. Valvola di comando	. Control valve	1	
3	3312 308 020	408388	. Guarnizione	. Gasket	1	
4	3312 308 025	452963	. Leva	. Lever	1	
5	0636 101 727	442377	. Vite T.E.	. Hex head screw	7	
6	0630 302 090	442372	. Rosetta	. Washer	8	
7	0637 006 157	455785	. Dado	. Nut	1	
8	0634 309 621	500065	. Guarnizione	. Gasket	1	
9	3312 308 034	500026	. Vite di fermo	. Stop screw	1	
10	0636 309 007	455756	. Tappo	. Plug	1	
11	0631 405 061	500107	. Tappo	. Plug	1	
12	0636 302 053	103465	. Tappo	. Plug	1	
13	0634 801 302	107410	. Rosetta	. Washer	3	
14	3312 308 037	500028	. Vite di guida	. Guide bolt	1	
15	3312 308 047	500044	. Molla	. Spring	1	
16	0635 460 014	106695	. Sfera	. Ball	2	
17	3312 308 029	455764	. Interruttore completo	. Neutral safety switch assy.	1	
18	001.105.0158	105527	. Guarnizione OR	. O-Ring	1	
19	3312 308 039	500030	. Boccia	. Bushing	1	
20	0630 502 005	500083	. Anello elastico	. Snap ring	1	
21	3312 308 038	500029	. Boccia	. Bushing	1	
22	3312 308 042	500032	. Molla per lubrificazione	. Spring	1	
23	0635 460 023	500097	. Sfera	. Ball	1	
24	3312 308 036	500027	. Distanziale	. Spacer	1	

ZF 63 IV - ZF 80 IV - ZF 80-1 IV

OLD ELECTRIC SELECTOR VALVE WITH PROPORTIONAL VALVES

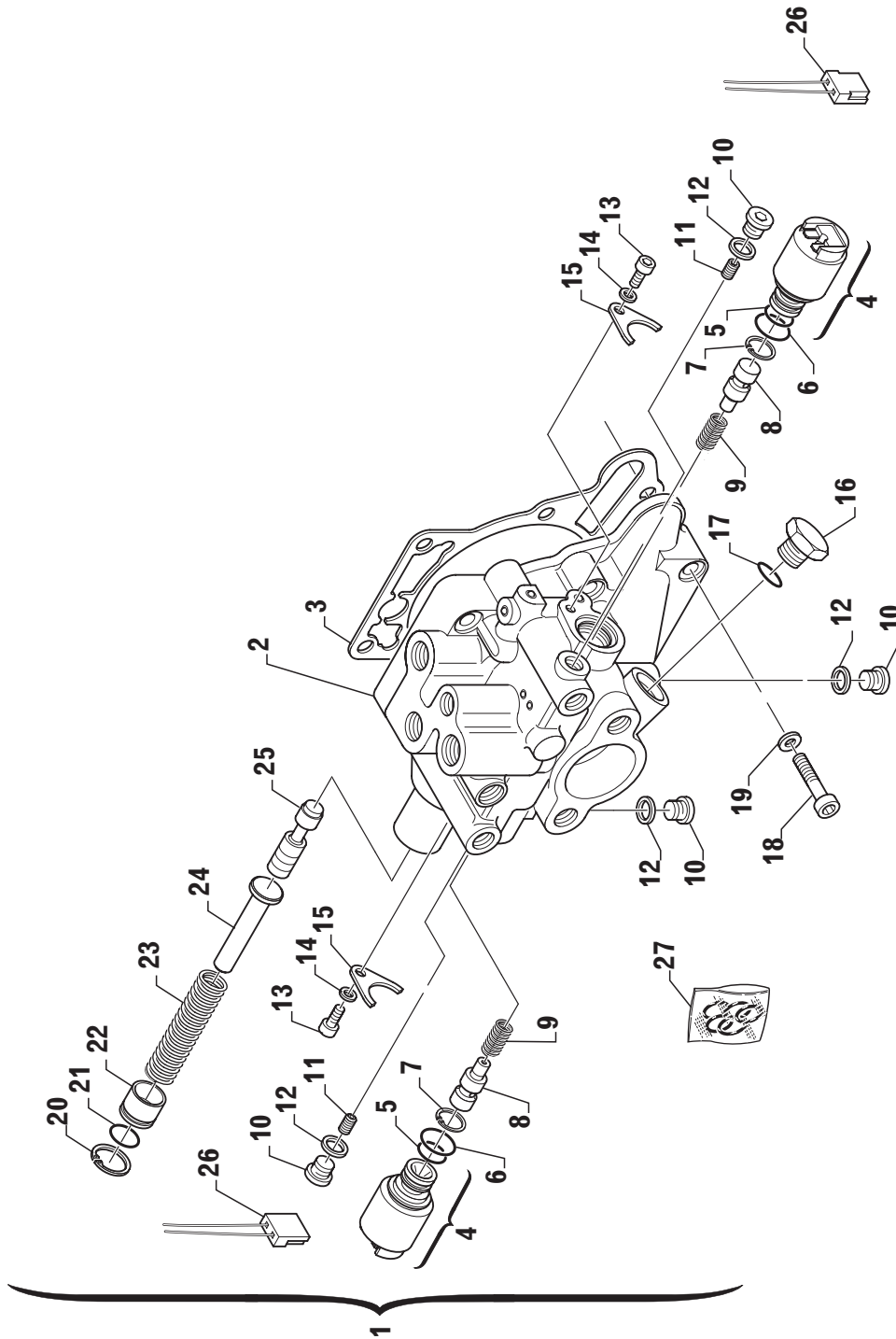



Pos.	Part number	Old P/N	Descrizione	Description	Q.tà Q.ty	Note
1	3312 199 004		Distributore elettrico	Electric selector valve	1	(1)
	3312 199 005		Distributore elettrico	Electric selector valve	1	(2)
	3313 108 003		Distributore elettrico	Electric selector valve	1	(3) Only for ZF 80-1 IV
	3313 108 004		Distributore elettrico	Electric selector valve	1	(4) Only for ZF 80-1 IV
2	☆		Valvola di comando	Control valve	1	
3	3312 308 020	408388	Guarnizione	Gasket	1	
4	3312 308 064	501634	Valvola proporzionale 12 V	Electric valve 12 V	2	
	3312 308 065	501635	Valvola proporzionale 24 V	Electric valve 24 V	2	
5	0634 430 651		Guarnizione OR	O-Ring	2	
6	0634 304 391	501524	Anello di tenuta	Piston ring	2	
7	0630 502 078	501528	Anello elastico	Snap ring	2	
8	3312 308 055	501651	Pistoncino valvola 2/3 vie	Valve piston	2	
9	3312 308 062	501533	Molla per pistone	Piston spring	2	
10	0636 302 053	103465	Tappo	Plug	4	
11	3312 308 059	501516	Grano	Drilled plug	2	
12	0634 801 302	107410	Rosetta	Washer	4	
13	0636 101 651	501525	Vite	Screw	2	
14	0630 001 096	501527	Rondella	Washer	2	
15	1043 326 045		Fermo valvola	Valve lock	2	
16	3312 308 063	501562	Tappo	Plug	1	
17	0634 306 524		Anello OR	O-Ring	1	
18	0636 101 727	442377	Vite	Screw	6	
19	0630 302 090	442372	Rosetta	Washer	6	
20	0630 532 004	501529	Anello elastico	Snap ring	1	
21	0634 304 309	501523	Anello di tenuta OR	O-Ring	1	
22	3312 308 058	501515	Tappo	Plug	1	
23	3312 308 040	500031	Molla	Spring	1	
24	3312 308 043	500038	Perno guida molla	Spring guide pin	1	
25	3312 308 017	500040	Pistoncino estraibile	Valve piston	1	
26	3312 117 001		Kit connettori	Connectors kit	1	
27	978.28.641.01	501751	Kit guarnizioni	Seals kit	1	

(1) Installare con 12 V - *to be instelled with 12 V power supply*

(2) Installare con 24 V - *to be instelled with 24 V power supply*

(3) Installare con 24 V - 26 bar - *to be instelled with 24 V power supply - 26 bar*

(4) Installare con 12 V - 26 bar - *to be instelled with 12 V power supply - 26 bar*

ZF 63 IV - ZF 80 IV - ZF 80-1 IV

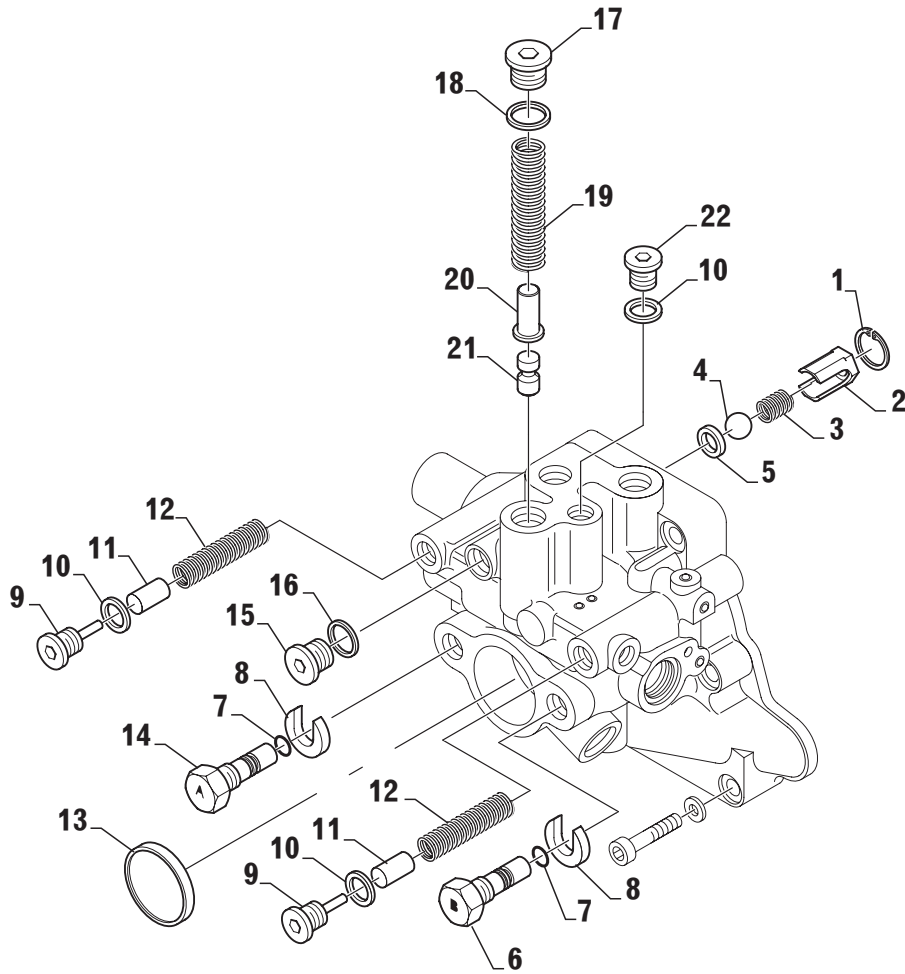



Pos.	Part number	Old P/N	Descrizione	Description	Q.tà Q.ty	Note
1	0630 502 005	500083	Anello elastico	Snap ring	1	
2	3312 308 038	500029	Boccola	Bushing	1	
3	3312 308 042	500032	Molla per lubrificazione	Spring	1	
4	0635 460 023	500097	Sfera	Ball	1	
5	3312 308 036	500027	Distanziale	Spacer	1	
6	3312 308 052	501497	Vite torna a casa "B"	Come home screw "B"	1	
7	0634 304 690	501522	Anello di tenuta OR	O-Ring	2	
8	3312 308 050	501495	Rondella	Washer	2	
9	3312 308 056	501513	Vite	Screw	2	
10	0634 801 302		Rosetta	Washer	3	
11	4656.306.013		Pistoncino ammortizzatore	Piston	2	
12	0732 042 539		Molla ammortizzatore	Spring	2	
13	0631 405 062	501530	Tappo	Plug	1	
14	3312 308 051	501496	Vite torna a casa "A"	Come home screw "A"	1	
15	0636 302 068	500744	Tappo	Plug	1	
16	0634 801 260	500897	Rosetta	Washer	1	
17	0636 302 065	501520	Vite	Screw	1	
18	0634 801 281	227851	Rosetta	Washer	1	
19	3312 308 061	501532	Molla	Spring	1	
20	3312 308 057	501514	Perno guida molla	Spring guide pin	1	
21	3312 308 053	501498	Pistoncino valvola riduzione	Valve piston	1	
22	0636 302 053	103465	Tappo	Plug	1	

ZF 63 IV - ZF 80 IV - ZF 80-1 IV

OLD ELECTRIC SELECTOR VALVE ON/OFF 12V, 26 BAR

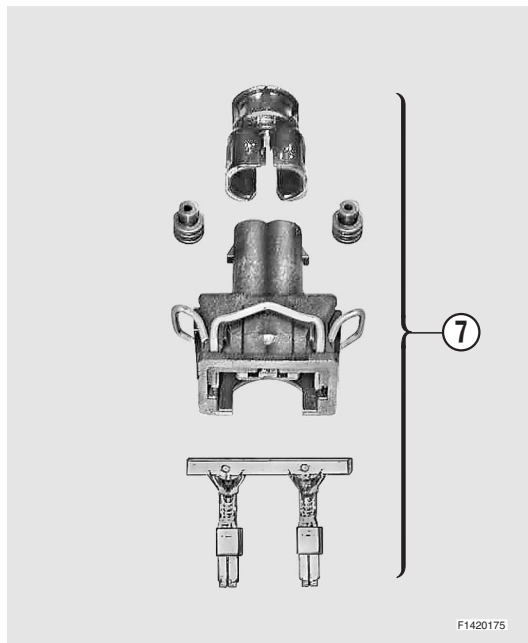
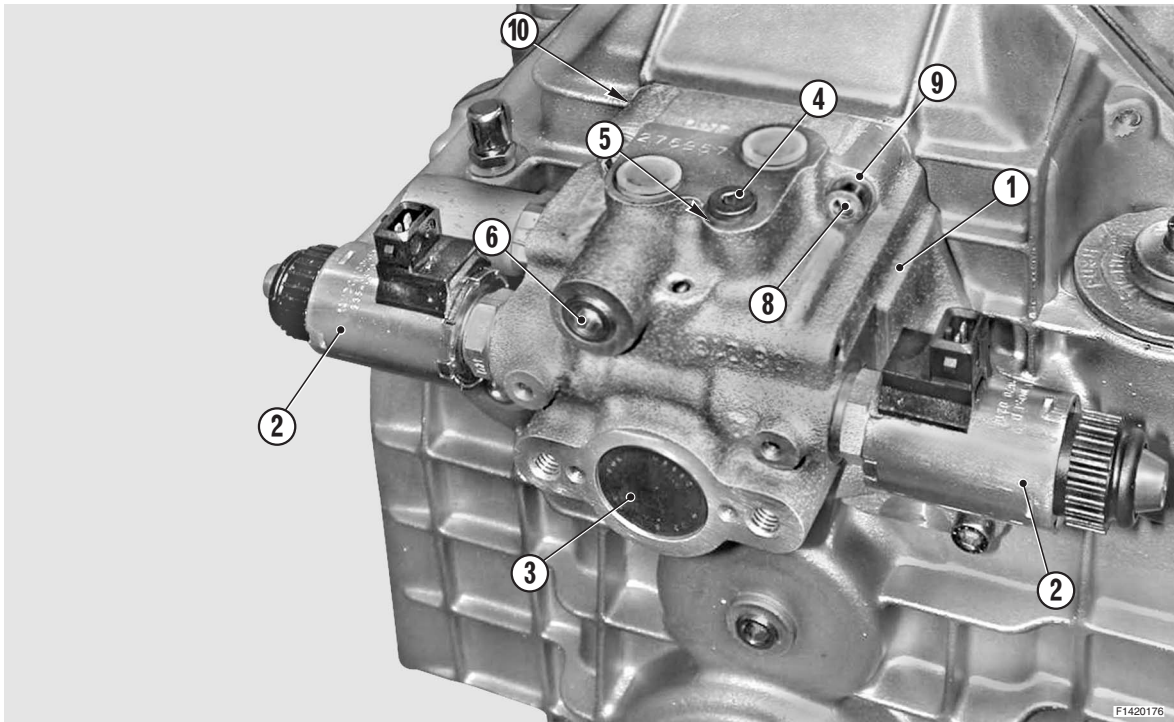



Pos.	Part number	Old P/N	Descrizione	Description	Q.tà Q.ty	Note
1	3312 199 015		Distributore elettrico 26 bar ON/OFF	Electric selector valve 26 bar ON/OFF	1	*
2	3312 308 069		Elettrovalvola ON/OFF 12V	Solenoid valve ON/OFF 12V	2	
3	0631 405 061		Tappo	Dummy plug	1	
4	0636 302 053		Tappo M10x1	Screw plug M10x1	1	Ma = 12 Nm
5	0634 801 302		Rosetta	Washer	1	
6	0636 309 007		Tappo	Screw plug	1	Ma = 30 Nm
7	3316 117 001		Assieme connettore	Connector kit	2	
8	0636 101 727		Vite T.E. M8x40	Cap screw M8x40	6	
9	0630 302 090		Rosetta	Spring washer	6	
10	3312 308 020		Guarnizione	Gasket	1	

* Installare con 12 V - *To be installed with 12 V power supply*



ZF 63 IV - ZF 80 IV - ZF 80-1 IV

NEW ELECTRIC SELECTOR VALVE ON/OFF 12V - 26 BAR

NEW ELECTRIC SELECTOR VALVE ON/OFF 24V - 26 BAR

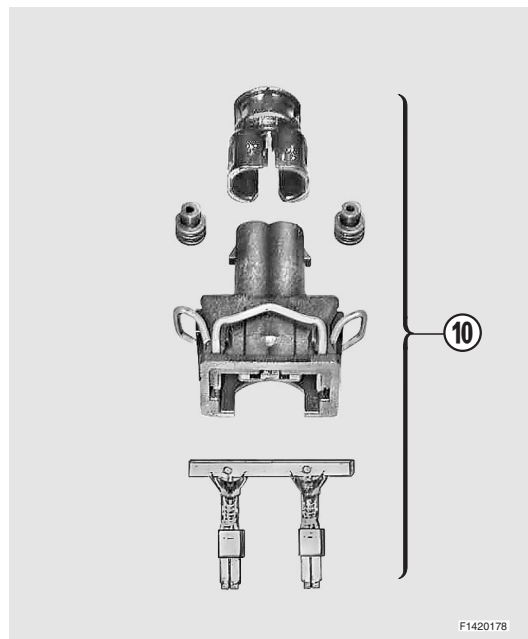
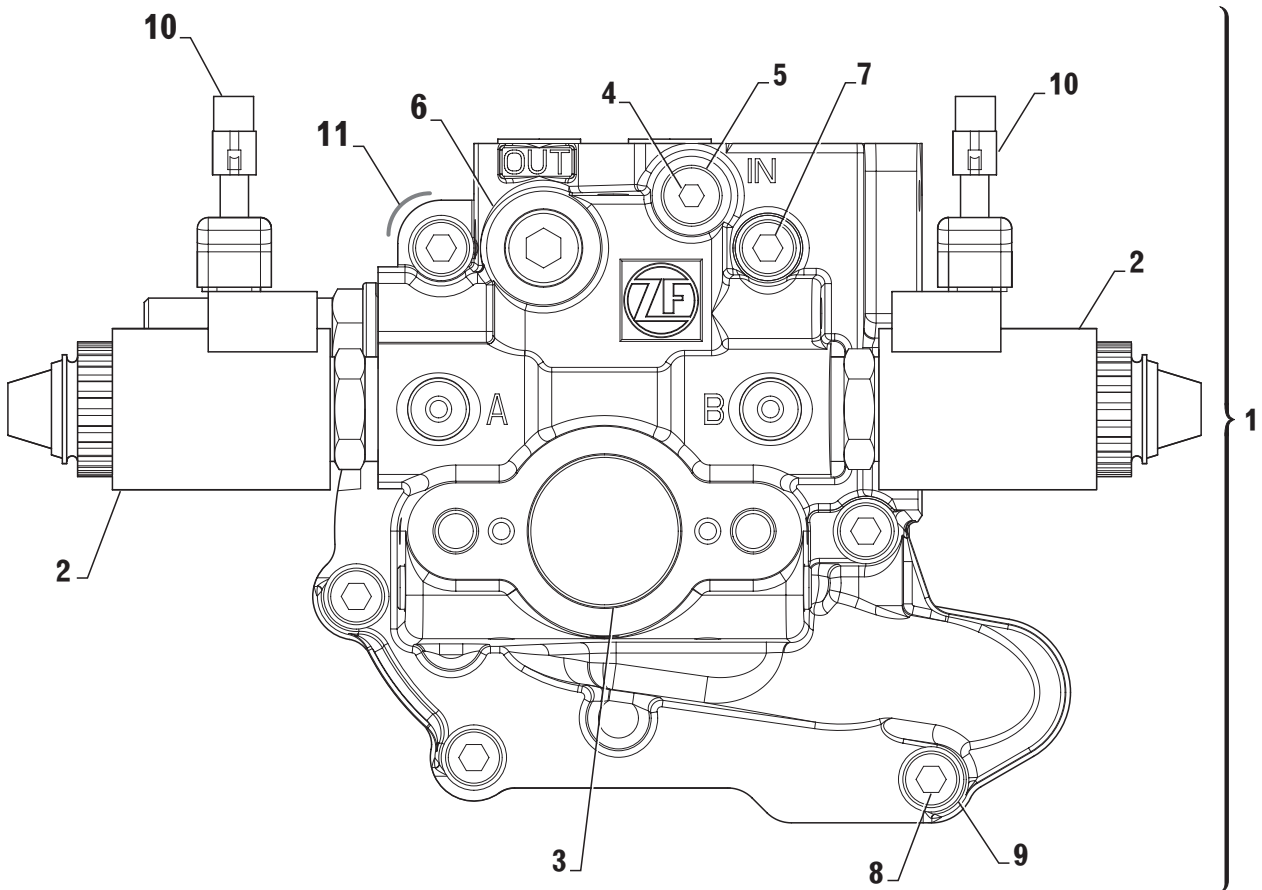



Pos.	Part number	Old P/N	Descrizione	Description	Q.tà Q.ty	Note
1	3312 199 063		Distributore elettrico ON/OFF 12V - 26 bar	Electric selector valve ON/OFF 12V - 26 bar	1	*
	3312 199 064		Distributore elettrico ON/OFF 24V - 26 bar	Electric selector valve ON/OFF 24V - 26 bar	1	* *
2	3312 308 069		Elettrovalvola ON/OFF 12V	Solenoid valve ON/OFF 12V	2	Ma = 20 Nm
	3312 308 106		Elettrovalvola ON/OFF 24V	Solenoid valve ON/OFF 24V	2	Ma = 20 Nm
3	0631 405 061		Tappo	Dummy plug	1	
4	0636 302 053		Tappo M10x1	Screw plug M10x1	1	Ma = 12 Nm
5	0634 801 302		Rosetta	Washer	1	
6	0636 309 007		Tappo	Screw plug	1	Ma = 35 Nm
7	0636 101 709		Vite T.E. M8x65	Cap screw M8x65	2	
8	0636 101 727		Vite T.E. M8x40	Cap screw M8x40	4	
9	0630 302 090		Rosetta elastica	Spring washer	6	
10	3316 117 001		Assieme connettore	Connector kit	2	
11	3312 308 020		Guarnizione	Gasket	1	

* Installare con 12 V - *To be installed with 12 V power supply*

* * Installare con 24 V - *To be installed with 24 V power supply*



Per convertire la elettrovalvola da 12V a 24V sostituire solo il solenoide con il ricambio a cod. 3312 199 062.
To transform the solenoid valve from 12V to 24V it will be enough to replace only the solenoid - available loosen P/N 3312 199 062.

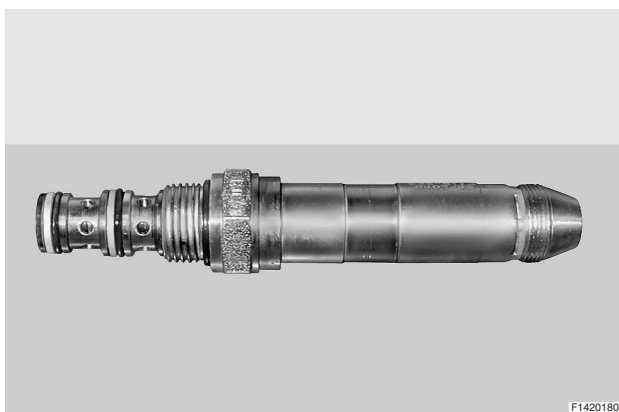

La valvola non è disponibile singolarmente ed è un componente comune alla versione 12V e 24V dell'elettrovalvola.
The valve is not available loosen and it is a common component both for 12V and 24V solenoid valve.

ZF 63 IV - ZF 80 IV - ZF 80-1 IV

**NEW ELECTRIC SELECTOR VALVE ON/OFF 12V - 26 BAR
WITH TROLLING VALVE**

**NEW ELECTRIC SELECTOR VALVE ON/OFF 24V - 26 BAR
WITH TROLLING VALVE**

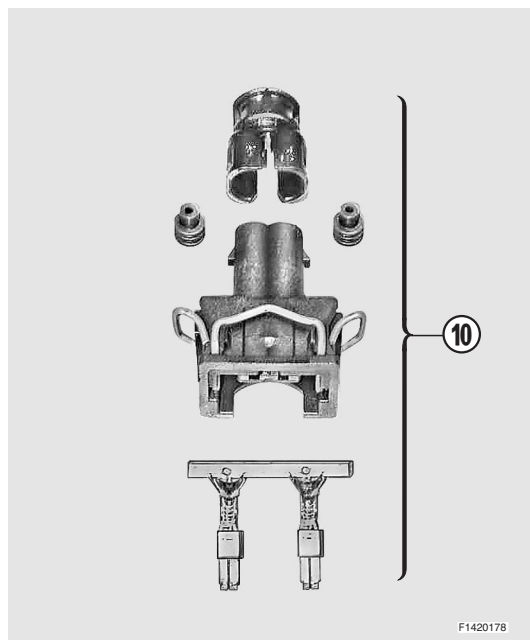
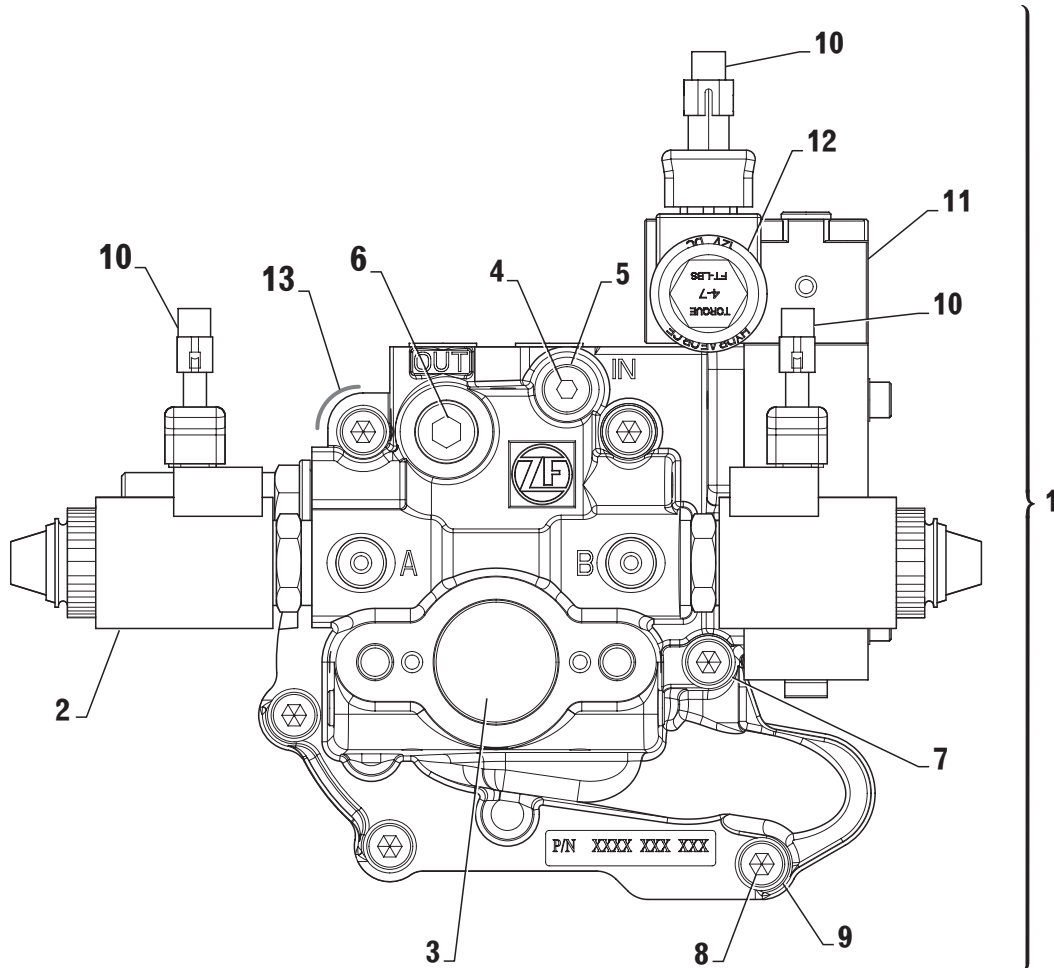



Pos.	Part number	Old P/N	Descrizione	Description	Q.tà Q.ty	Note
1	3312 199 065		Distributore elettrico ON/OFF 12V, 26 bar con TV	Electric selector valve ON/OFF 12V, 26 bar with Trolling valve	1	*
	3312 199 066		Distributore elettrico ON/OFF 24V, 26 bar con TV	Electric selector valve ON/OFF 24V, 26 bar with Trolling valve	1	* *
2	3312 308 069		Elettrovalvola ON/OFF 12V, 26 BAR	Solenoid valve ON/OFF 12V, 26 bar	2	Ma = 20 Nm
	3312 308 106		Elettrovalvola ON/OFF 24V, 26 bar	Solenoid valve ON/OFF 24V, 26 bar	2	Ma = 20 Nm
3	0631 405 061		Tappo	Dummy plug	1	
4	0636 302 053		Tappo a vite M10x1	Screw plug M10x1	1	Ma = 12 Nm
5	0634 801 302		Anello di tenuta	Sealing ring	1	
6	0636 309 007		Tappo a vite	Screw plug	1	Ma = 35 Nm
7	0636 101 709		Vite TCEI M8x65	Cap screw M8x65	2	
8	0636 101 727		Vite TCEI M8x40	Cap screw M8x40	4	
9	0630 302 090		Rosetta elastica	Spring washer	6	
10	3316 117 001		Assieme connettore	Connector kit	3	
11	3312 108 027		Trolling valve	Trolling device	1	
12	3312 308 096		Valvola proporzionale 12V	Proportional valve 12V	1	Ma = 27 Nm
	3312 308 124		Valvola proporzionale 24V	Proportional valve 24V	1	Ma = 27 Nm
13	3312 308 020		Guarnizione	Gasket	1	

* Installare con 12 V - *To be installed with 12 V power supply*

* * Installare con 24 V - *To be installed with 24 V power supply*



Per convertire la elettrovalvola da 12V a 24V sostituire solo il solenoide con il ricambio a cod. 3312 199 062.
To transform the solenoid valve from 12V to 24V it will be enough to replace only the solenoid - available loosen P/N 3312 199 062.



La valvola non è disponibile singolarmente ed è un componente comune alla versione 12V e 24V dell'elettrovalvola.
The valve is not available loosen and it is a common component both for 12V and 24V solenoid valve.

**COMPOSIZIONE KIT ZF 63 IV - ZF 63 IV KIT COMPONENTS**

Fig.	Pos.	Part number	Old P/N	Descrizione	Description	Q.ty
-	-	3312 199 020	500423	Kit guarnizioni e anelli elastici	Seal kit & piston rings	1
1	29	3312 301 030	413883	. Paraolio entrata	. Input shaft seal	1
1	4	0634 319 133	444070	. Paraolio uscita	. Output shaft seal	1
1	30	0634 319 134	444071	. Paraolio uscita	. Output shaft seal	1
3	3	3312 308 020	408388	. Guarnizione	. Gasket	1
3	8	0634 309 621	500065	. Anello di tenuta	. Seal	1
2	4	3312 302 041	447038	. Anello elastico	. Piston ring	3
1	22	0634 304 405	501211	. Guarnizione OR	. O-Ring	1
1	11	0634 304 688	442731	. Guarnizione OR	. O-Ring	1
1	12	0634 306 204	105542	. Guarnizione OR	. O-Ring	1
1	20	3312 301 008	439653	. Guarnizione	. Gasket	1
<hr/>						
-	-	3312 199 021	500433	Kit guarnizioni e frizioni	Seal kit & clutch kit	1
-	-	3312 199 020	504230	. Kit guarnizioni e anelli elastici	. Seal kit & piston rings	1
2	14	3312 302 009	455786	. Disco frizione interno	. Inner clutch disc	8
2	13	3312 302 008	455787	. Disco frizione esterno	. Outer clutch disc	10
<hr/>						
-	-	3312 199 022	501217	Kit cuscinetti	Bearing kit	
2	5	0635 501 940	-	. Cuscinetto a rullini conici	. Tapered roller bearing	1
2	8	3312 302 040	441438	. Cuscinetto a rulli	. Needle bearing	4
2	22, 26	0635 501 937	447754	. Cuscinetto a rullini conici	. Tapered roller bearing	1
2	24	0635 501 942	-	. Cuscinetto a rullini conici	. Tapered roller bearing	1
2	25	0635 501 941	-	. Cuscinetto a rullini conici	. Tapered roller bearing	1
2	27	0635 372 007	106652	. Cuscinetto a rullini conici	. Tapered roller bearing	1
2	29	0635 370 020	159808	. Cuscinetto a rullini conici	. Tapered roller bearing	1
2	30	0635 376 005	446130	. Cuscinetto a rullini conici	. Tapered roller bearing	1
2	23	3312 302 023	277213	. Spessore 0,1 mm	. Shim 0.1 mm	2
2	23	3312 302 024	277214	. Spessore 0,15 mm	. Shim 0.15 mm	2
2	23	3312 302 025	277215	. Spessore 0,2 mm	. Shim 0.2 mm	2
2	23	3312 302 026	277216	. Spessore 0,5 mm	. Shim 0,5 mm	2
2	28	3312 304 022	439393	. Spessore 0,1 mm	. Shim 0.1 mm	2
2	28	3312 304 023	439394	. Spessore 0,15 mm	. Shim 0.15 mm	2
2	28	3312 304 024	439395	. Spessore 0,3 mm	. Shim 0.3 mm	2
2	28	3312 304 025	439396	. Spessore 0,5 mm	. Shim 0.5 mm	2

COMPOSIZIONE KIT ZF 80 IV - ZF 80-1 IV - ZF 80 IV - ZF 80-1 IV KIT COMPONENTS

Fig.	Pos.	Part number	Old P/N	Descrizione	Description	Q.ty
-	-	3313 199 023	500425	Kit guarnizioni e anelli elastici	Seal kit & piston rings	1
1	29	3312 301 030	413883	. Paraolio entrata	. Input shaft seal	1
1	5	0634 309 631	105113	. Paraolio uscita	. Output shaft seal	1
1	30	0634 309 619	480762	. Paraolio uscita	. Output shaft seal	1
3	3	3312 308 020	408388	. Guarnizione	. Gasket	1
3	8	0634 309 621	500065	. Anello di tenuta	. Seal	1
2	4	3312 302 041	447038	. Anello elastico	. Piston ring	3
1	23	0634 304 405	501211	. Guarnizione OR	. O-Ring	1
1	12	0634 304 688	442731	. Guarnizione OR	. O-Ring	1
1	13	0634 306 204	105542	. Guarnizione OR	. O-Ring	1
1	21	3312 301 008	439653	. Guarnizione	. Gasket	1
-	-	3313 199 024	500435	Kit guarnizioni e frizioni	Seal kit & clutch kit	1
-	-	3313 199 023	500425	. Kit guarnizioni e anelli elastici	. Seal kit & piston rings	1
2	16	3312 302 009	455786	. Disco frizione interno	. Inner clutch disc	10
2	15	3312 302 008	455787	. Disco frizione esterno	. Outer clutch disc	12
-	-	3313 199 025	501219	Kit cuscinetti	Bearing kit	
2	5,26	0635 501 937	447754	. Cuscinetto a rullini conici	. Tapered roller bearing	2
2	9	3312 302 040	441438	. Cuscinetto a rulli	. Needle bearing	4
2	24	0635 501 939	-	. Cuscinetto a rullini conici	. Tapered roller bearing	1
2	27	0635 501 938	333859	. Cuscinetto a rullini conici	. Tapered roller bearing	1
2	28	0635 374 005	229784	. Cuscinetto a rullini conici	. Tapered roller bearing	1
2	29	0635 372 007	106652	. Cuscinetto a rullini conici	. Tapered roller bearing	1
2	32	0635 370 017	464199	. Cuscinetto a rullini conici	. Tapered roller bearing	1
2	33	0635 373 010	480757	. Cuscinetto a rullini conici	. Tapered roller bearing	1
2	25	3313 302 042	439630	. Spessore 0,1 mm	. Shim 0.1 mm	2
2	25	3313 302 043	439631	. Spessore 0,15 mm	. Shim 0.15 mm	2
2	25	3313 302 044	439632	. Spessore 0,2 mm	. Shim 0.2 mm	2
2	25	3313 302 045	439633	. Spessore 0,5 mm	. Shim 0,5 mm	2
2	25	3313 302 046	439634	. Spessore 0,1 mm	. Shim 0.1 mm	2
2	30	3312 304 022	439393	. Spessore 0,1 mm	. Shim 0.1 mm	2
2	30	3312 304 023	439394	. Spessore 0,15 mm	. Shim 0.15 mm	2
2	30	3312 304 024	439395	. Spessore 0,3 mm	. Shim 0.3 mm	2
2	30	3312 304 025	439396	. Spessore 0,5 mm	. Shim 0.5 mm	2
2	31	3313 304 031	477560	. Spessore 0,1 mm	. Shim 0.1 mm	2
2	31	3313 304 030	477558	. Spessore 0,15 mm	. Shim 0.15 mm	2
2	31	3313 304 029	477557	. Spessore 0,2 mm	. Shim 0.2 mm	2
2	31	3313 304 028	447551	. Spessore 0,5 mm	. Shim 0.5 mm	2



12. SPARE PARTS LIST ZF 80 IV, ZF 80 - 1 IV

Preface

The spare parts list is only valid for the type and versions of transmission, as shown below.

You will find the transmission type and version on your transmission name plate.

If the type and version indicated differs from that printed in this Manual, the relative Spare Parts List should be ordered from ZF HURTH MARINE.

The indicated dimensions and standards are as such not enough for ordering parts.

When ordering parts, please state:

- Transmission type
- Transmission version
- Serial number
- Item no.
- Part name
- Identification no.
- quantity of parts required.

The spare parts list is referring to the following versions:

ZF 80 IV	versions 029 (1.21 R); 030 (1.40 R); 031 (1.64 R); 032 (2.01 R); 033 (2.49 R)
ZF 80-1 IV	versions 034 (1.21 R); 035 (1.40 R); 036 (1.64 R); 037 (2.01 R); 038 (2.49 R);

Name plate

The name plate is mounted to the transmission.

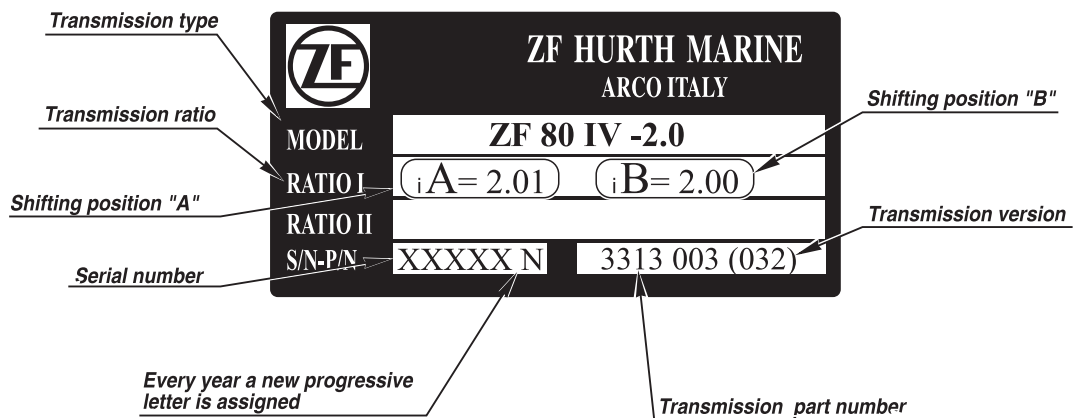

ZF 80 IV versions 029 - 030 - 031 - 032 - 033
ZF 80-1 IV versions 034 - 035 - 036 - 037 - 038

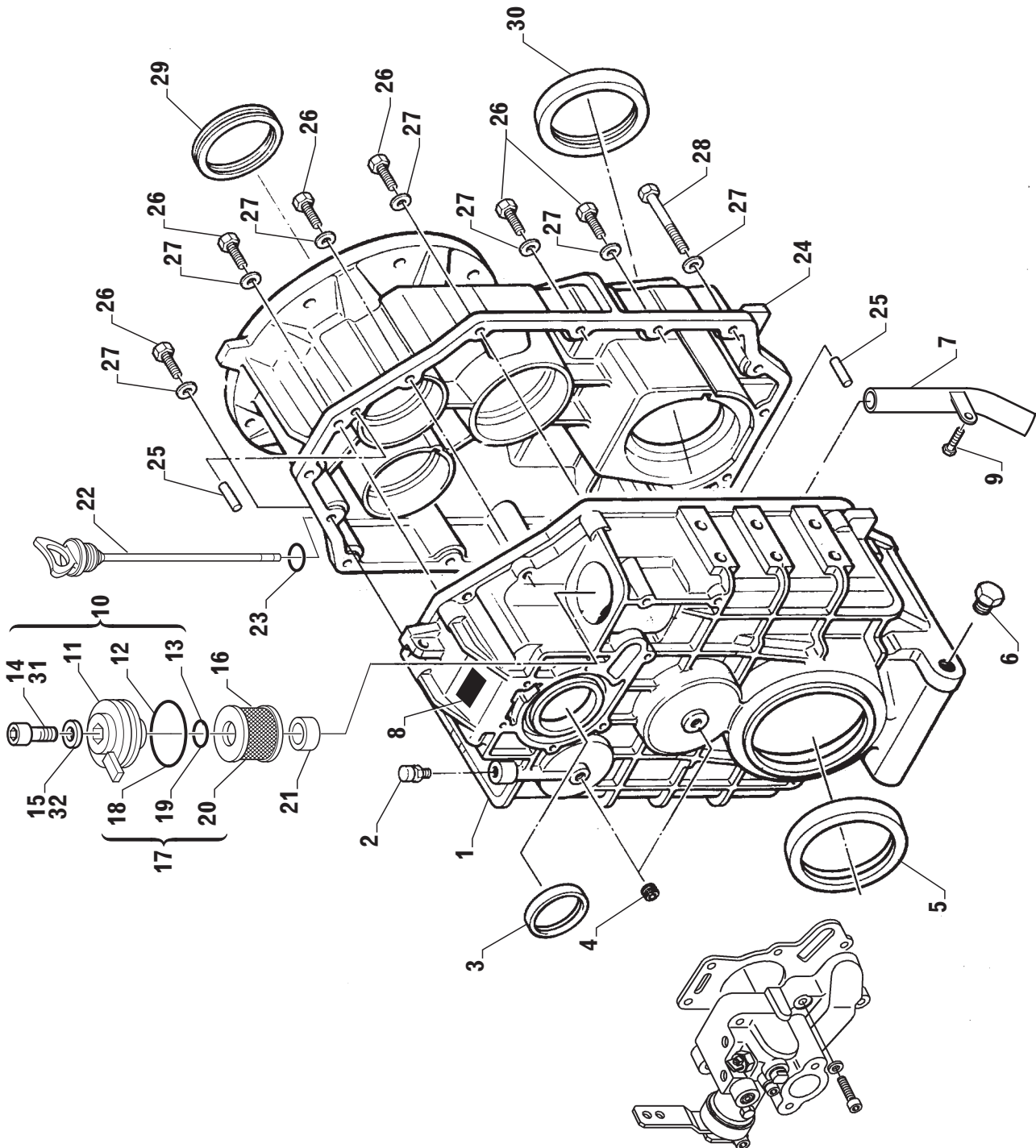



Pos.	Part number	Old P/N	Descrizione	Description	Q.tà Q.ty	Note
1	3313 199 080		Assieme scatola	Housing, assy.	1	
	3313 301 025		. Scatola	. Housing	1	
	3313 301 026		. Tubo aspirazione con supporto	. Suction pipe with support	1	
	0636 101 411		. Vite	. Screw	1	
	3312 301 008		. Guarnizione	. Gasket	1	
2	3311 301 002	442369	Valvola di sfiato	Breather valve	1	
3	3313 301 014	462997	Anello centratore	Centering ring	1	up to s/n XXXXXR
4	0636 301 041	442373	Tappo M16x1,5	Plug M16x1.5	2	
5	0634 309 631	105113	Paraolio uscita	Output shaft seal	1	
6	3312 301 017	469691	Tappo	Plug	1	
7	3313 301 026		Tubo aspirazione con supporto	Suction pipe with support	1	
8	3312 301 001		Targhetta di identificazione	Name plate	1	
9	0636 101 411	102879	Vite T.E. M6x16 (fascetta tubo aspirazione)	Hex head screw M6x16 (suction pipe clamp)	1	
10	3312 101 003	500484	Coperchio filtro completo	Filter cover, assy.	1	
11	☆		. Coperchio filtro	. Filter cover	1	
12	0634 304 688	442731	. Guarnizione OR	. O-Ring	1	
13	0634 306 204	105542	. Guarnizione OR	. O-Ring	1	
14	0630 001 085	167010	. Rosetta	. Washer	1	
15	0636 101 475	320202	. Vite M8x30	. Screw M8x30	1	
16	3312 301 007	438637	Filtro olio	Oil filter	1	* old part number
17	3312 199 031	463772	Filtro olio completo	Oil filter, assy	1	
18	0634 304 688	442731	. Guarnizione OR	. O-Ring	1	
19	0634 306 204	105542	. Guarnizione OR	. O-Ring	1	
20	3312 301 037		. Filtro olio	. Oil filter	1	* new part number
21	3312 301 008	439653	Guarnizione	Gasket	1	
22	3313 201 002	500990	Asta livello olio + OR	Oil dipstick + OR	1	
23	0634 304 405	501211	. Guarnizione OR	. O-Ring	1	
24	3313 301 016	480425	Coperchio	Cover (housing)	1	
25	0631 315 520	335817	Spina	Locator pin	2	
26	0636 015 227	442375	Vite T.E. M10x35	Hex head screw M10x35	15	
27	0630 302 091	442371	Rosetta	Washer	16	
28	0636 010 463	315548	Vite T.E. M10x70	Hex head screw M10x70	1	
29	3312 301 030	413883	Paraolio entrata	Input shaft seal	1	
30	0634 309 619	480762	Paraolio uscita	Output shaft seal	1	
31	0630 001 085	167010	Rosetta	Washer	1	
32	0636 101 475	320202	Vite M8x30	Screw M8x30	1	

* Fornito solamento incluso nel Kit filtro olio p/n 3312 199 031
Supplied only included in the oil filter Kit p/n 3312 199 031

ZF 80 IV versions 029 - 030 - 031 - 032 - 033
ZF 80-1 IV versions 034 - 035 - 036 - 037 - 038

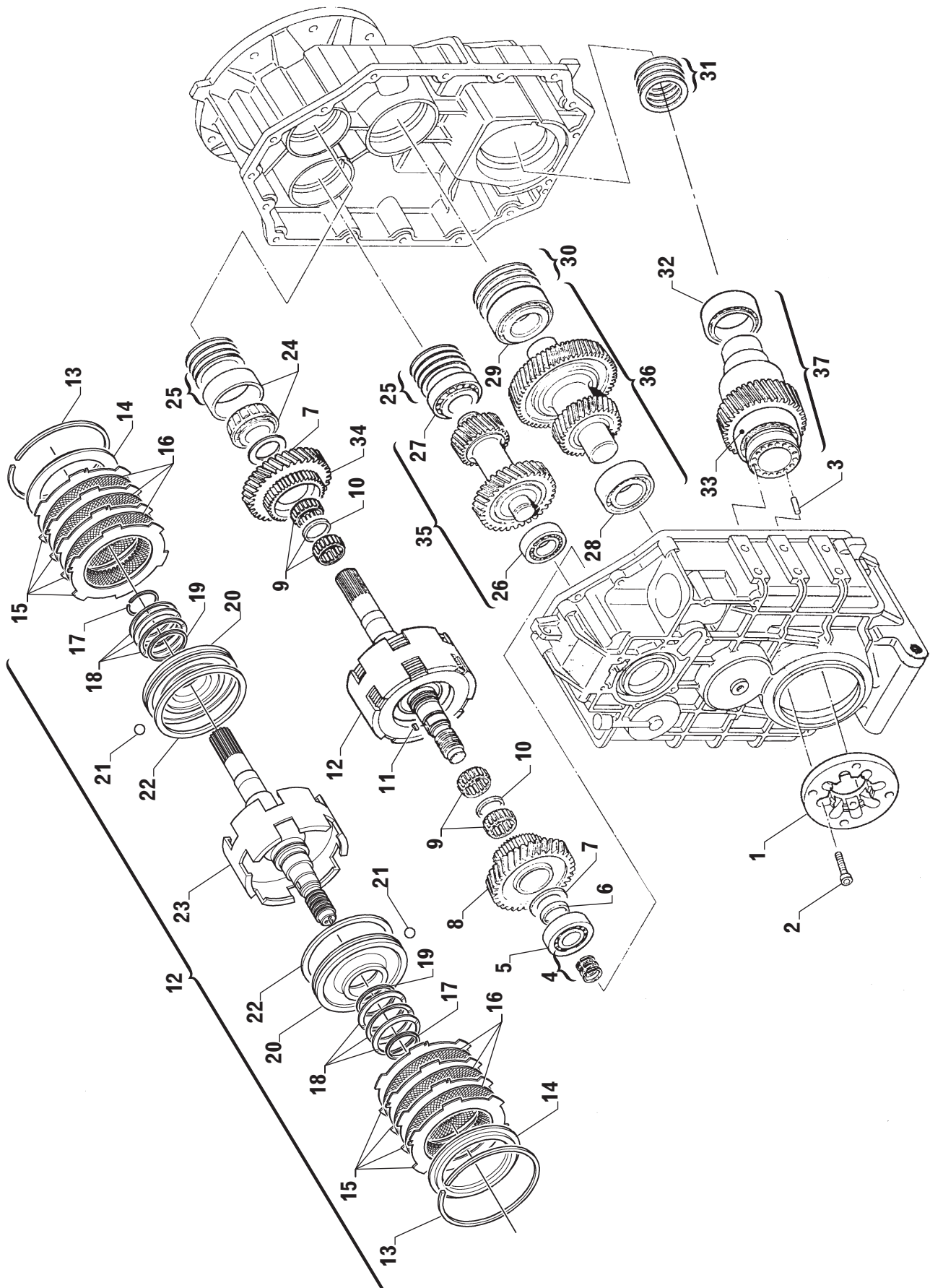



Pos.	Part number	Old P/N	Descrizione	Description	Q.tà Q.ty	Note
1	3313 304 019	480566	Flangia	Flange	1	
2	0636 101 072	312590	Vite	Screw	8	
3	0631 313 056	104661	Spina	Locator pin	4	
4	3312 302 041	447038	Anello di tenuta	Piston ring	3	
5	0635 501 937	447754	Cuscinetto a rulli conici	Tapered roller bearing	1	
6	3313 302 037	488628	Distanziale	Spacer	1	Ratio I = 1.2 - 1.4
7	3313 302 023	457823	Rasamento	Butting ring	2	
8	3313 302 056		Ingranaggio Z3 = 38	Reverse gear Z3 = 38	1	●
	3313 302 057		Ingranaggio Z3 = 38	Reverse gear Z3 = 38	1	● ●
9	3312 302 040	441438	Cuscinetto a rullini	Needle bearing	4	
10	3313 302 030	439533	Distanziale	Spacer	2	
11	0631 501 062	437956	Chiavetta	Key	1	
12	3313 199 075		Albero di ingresso completo	Input shaft, assy.	1	Ratio I = 1.6 - 2.0 -2.5
	3313 199 082		Albero di ingresso completo	Input shaft, assy.	1	Ratio I = 1.2 - 1.4
13	0630 513 065		. Anello elastico	. Snap ring	2	
14	3319 302 003		. Disco finale	. End disc	2	
15	3319 302 001		. Disco frizione esterno	. Outer clutch disc	10	
16	3319 302 006		. Disco frizione interno	. Inner clutch disc	8	
17	0630 501 038	500076	. Anello di ritegno	. Retainer ring	2	
18	3313 302 059		. Molla a tazza	. Cup spring	6	
19	0634 402 178	500066	. Anello interno	. Inner clutch piston ring	2	
20	3319 302 004		. Pistone	. Clutch piston	2	
21	0635 460 006	106690	. Sfera	. Ball	2	
22	0634 402 177		. Anello esterno	. Outer clutch piston ring	2	
23	3313 199 076		. Albero di ingresso + cilindro frizione	. Input shaft and clutch housing	1	Ratio I = 1.6 - 2.0 -2.5
	3313 199 084		. Albero di ingresso + cilindro frizione	. Input shaft and clutch housing	1	Ratio I = 1.2 - 1.4
24	0635 501 939		Cuscinetto a rulli conici	Tapered roller bearing	1	
25	3313 302 042	439630	Spessore 0,1 mm	Shim 0.1 mm	2	
	3313 302 043	439631	Spessore 0,15 mm	Shim 0.15 mm	2	
	3313 302 044	439632	Spessore 0,2 mm	Shim 0.2 mm	2	
	3313 302 045	439633	Spessore 0,5 mm	Shim 0.5 mm	2	
	3313 302 046	439634	Spessore 1,0 mm	Shim 1.0 mm	2	
26	0635 501 937	447754	Cuscinetto a rulli conici	Tapered roller bearing	1	
27	0635 501 938	333859	Cuscinetto a rulli conici	Tapered roller bearing	1	
28	0635 374 005	229784	Cuscinetto a rulli conici	Tapered roller bearing	1	
29	0635 372 007	106652	Cuscinetto a rulli conici	Tapered roller bearing	1	
30	3312 304 022	439393	Spessore 0,1 mm	Shim 0.1 mm	2	
	3312 304 023	439394	Spessore 0,15 mm	Shim 0.15 mm	2	
	3312 304 024	439395	Spessore 0,3 mm	Shim 0.3 mm	2	
	3312 304 025	439396	Spessore 0,5 mm	Shim 0.5 mm	2	
31	3313 304 031	477560	Spessore 0,1 mm	Shim 0.1 mm	2	
	3313 304 030	477558	Spessore 0,15 mm	Shim 0.15 mm	2	
	3313 304 029	477557	Spessore 0,2 mm	Shim 0.2 mm	2	
	3313 304 028	477551	Spessore 0,5 mm	Shim 0.5 mm	2	
32	0635 370 017	464199	Cuscinetto a rulli conici	Tapered roller bearing	1	
33	0635 373 010	480757	Cuscinetto a rulli conici	Tapered roller bearing	1	

● Solo per ZF 80 IV (tutti i rapporti) e ZF 80-1 IV Rapporto I=2.49 - Only for ZF 80 IV (all ratios) and ZF 80-1 IV Ratio I=2.49

● ● Solo per ZF 80-1 IV - Escluso rapporto I=2.49 - Only for ZF 80-1 IV - No ratio I=2.49



Pos.	Part number	Old P/N	Descrizione	Description	Q.tà Q.ty	Note
SOLO PER ZF 80 IV - ONLY FOR ZF 80 IV						
Vers. 029 (Rapporto I = 1,21)				Vers. 029 (Ratio I = 1.21)		
34	3313 302 051		Ingranaggio Z1 = 32	Forward gear Z1 = 32	1	
35	3313 199 085		Albero intermedio Z4 = 39, Z5 = 33	Reversing shaft Z4 = 39, Z5 = 33	1	*
36	3313 199 086		Albero intermedio Z2 = 47, Z6 = 45	Intermediate shaft Z2 = 47, Z6 = 45	1	*
37	3313 199 043	500516	Albero di uscita Z7 = 37	Output shaft Z7 = 37	1	*
Vers. 030 (Rapporto I = 1,40)				Vers. 030 (Ratio I = 1.40)		
34	3313 302 051		Ingranaggio Z1 = 32	Forward gear Z1 = 32	1	
35	3313 199 085		Albero intermedio Z4 = 39, Z5 = 33	Reversing shaft Z4 = 39, Z5 = 33	1	*
36	3313 199 087		Albero intermedio Z2 = 47, Z6 = 42	Intermediate shaft Z2 = 47, Z6 = 42	1	*
37	3313 199 045	500517	Albero di uscita Z7 = 40	Output shaft Z7 = 40	1	*
Vers. 031 (Rapporto I = 1,64)				Vers. 031 (Ratio I = 1.64)		
34	3313 302 052		Ingranaggio Z1 = 33	Forward gear Z1 = 33	1	
35	3313 199 088		Albero intermedio Z4 = 39, Z5 = 34	Intermediate shaft Z4 = 39, Z5 = 34	1	*
36	3313 199 089		Albero intermedio Z2 = 46, Z6 = 39	Intermediate shaft Z2 = 46, Z6 = 39	1	*
37	3313 199 048	486680	Albero uscita Z7 = 46	Output shaft Z7 = 46	1	*
Vers. 032 (Rapporto I = 2,01)				Vers. 032 (Ratio I = 2.01)		
34	3313 202 017		Ingranaggio Z1 = 31	Forward gear Z1 = 31	1	
35	3313 199 090		Albero intermedio Z4 = 39, Z5 = 32	Reversing shaft Z4 = 39, Z5 = 32	1	*
36	3313 199 091		Albero intermedio Z2 = 49, Z6 = 37	Intermediate shaft Z2 = 49, Z6 = 37	1	*
37	3313 199 094		Albero di uscita Z7 = 47	Output shaft Z7 = 47	1	*
Vers. 033 (Rapporto I = 2,49)				Vers. 033 (Ratio I = 2.49)		
34	3313 202 018		Ingranaggio Z1 = 27	Forward gear Z1 = 27	1	
35	3313 199 092		Albero intermedio Z4 = 39, Z5 = 28	Intermediate shaft Z4 = 39, Z5 = 28	1	*
36	3313 199 093		Albero intermedio Z2 = 53, Z6 = 37	Intermediate shaft Z2 = 53, Z6 = 37	1	*
37	3313 199 094		Albero di uscita Z7 = 47	Output shaft Z7 = 47	1	*
SOLO PER ZF 80-1 IV - ONLY FOR ZF 80-1 IV						
Vers. 034 (Rapporto I = 1,21)				Vers. 034 (Ratio I = 1.21)		
34	3313 302 055		Ingranaggio Z1 = 32	Forward gear Z1 = 32	1	
35	3313 199 095		Albero d'inversione Z4 = 39, Z5 = 33	Reversing shaft Z4 = 39, Z5 = 33	1	*
36	3313 199 096		Albero intermedio Z2 = 47, Z6 = 45	Intermediate shaft Z2 = 47, Z6 = 45	1	*
37	3313 199 043	500516	Albero di uscita Z7 = 37	Output shaft Z7 = 37	1	*
Vers.035 (Rapporto I = 1,40) Vers. 035 (Ratio I = 1.40)						
34	3313 302 055		Ingranaggio Z1 = 32	Forward gear Z1 = 32	1	
35	3313 199 095		Albero d'inversione Z4 = 39, Z5 = 33	Reversing shaft Z4 = 39, Z5 = 33	1	*
36	3313 199 101		Albero intermedio Z2 = 47, Z6 = 42	Intermediate shaft Z2 = 47, Z6 = 42	1	*
37	3313 199 060		Albero di uscita Z7 = 40	Output shaft Z7 = 40	1	*
Vers. 036 (Rapporto I = 1,64)				Vers. 036 (Ratio I = 1.64)		
34	3313 302 052		Ingranaggio Z1 = 33	Forward gear Z1 = 33	1	
35	3313 199 102		Albero d'inversione Z4 = 39, Z5 = 34	Reversing shaft Z4 = 39, Z5 = 34	1	*
36	3313 199 103		Albero intermedio Z2 = 46, Z6 = 39	Intermediate shaft Z2 = 46, Z6 = 39	1	*
37	3313 199 063		Albero di uscita Z7 = 46	Output shaft Z7 = 46	1	*
Vers. 037 (Rapporto I = 2,01)				Vers. 037 (Ratio I = 2.01)		
34	3313 202 017		Ingranaggio Z1 = 31	Forward gear Z1 = 31	1	
35	3313 199 104		Albero d'inversione Z4 = 39, Z5 = 32	Reversing shaft Z4 = 39, Z5 = 32	1	*
36	3313 199 091		Albero intermedio Z2 = 49, Z6 = 37	Intermediate shaft Z2 = 49, Z6 = 37	1	*
37	3313 199 094		Albero di uscita Z7 = 47	Output shaft Z7 = 47	1	*
Vers. 038 (Rapporto I = 2,49)				Vers. 038 (Ratio I = 2.49)		
34	3313 202 019		Ingranaggio Z1 = 27	Forward gear Z1 = 27	1	
35	3313 199 098		Albero d'inversione Z4 = 39, Z5 = 28	Reversing shaft Z4 = 39, Z5 = 28	1	*
36	3313 199 099		Albero intermedio Z2 = 53, Z6 = 37	Intermediate shaft Z2 = 53, Z6 = 37	1	*
37	3313 199 100		Albero di uscita Z7 = 47	Output shaft Z7 = 47	1	*

* Cuscinetti a rulli conici già assemblati - *Tapered roller bearings already assembled*

ZF 80 IV versions 029 - 030 - 031 - 032 - 033
ZF 80-1 IV versions 034 - 035 - 036 - 037 - 038

MECHANICAL SELECTOR VALVE

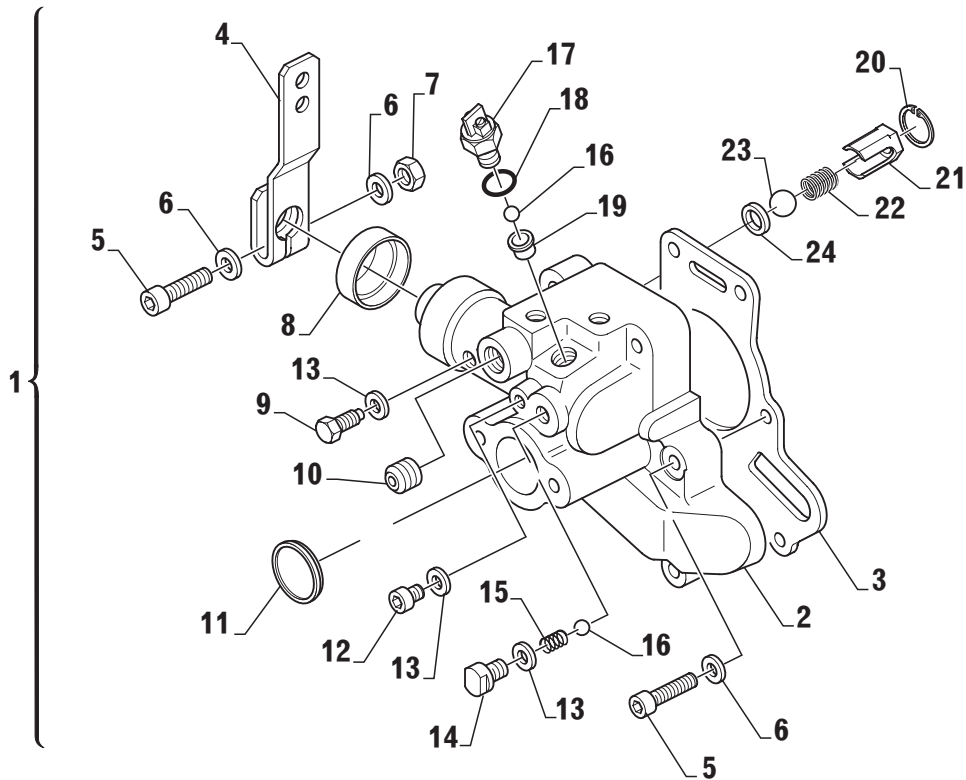



Pos.	Part number	Old P/N	Descrizione	Description	Q.tà Q.ty	Note
1	3312 108 001		Valvola di comando completa	Mechanical selector valve 23 bar	1	Only for ZF 80-1 IV
	3313 108 001		Valvola di comando alta velocità	Mechanical selector valve 26 bar	1	
2	☆		. Valvola di comando	. Control valve	1	
3	3312 308 020	408388	. Guarnizione	. Gasket	1	
4	3312 308 025	452963	. Leva	. Lever	1	
5	0636 101 727	442377	. Vite T.E.	. Hex head screw	7	
6	0630 302 090	442372	. Rosetta	. Washer	8	
7	0637 006 157	455785	. Dado	. Nut	1	
8	0634 309 621	500065	. Guarnizione	. Gasket	1	
9	3312 308 034	500026	. Vite di fermo	. Stop screw	1	
10	0636 309 007	455756	. Tappo	. Plug	1	
11	0631 405 061	500107	. Tappo	. Plug	1	
12	0636 302 053	103465	. Tappo	. Plug	1	
13	0634 801 302	107410	. Rosetta	. Washer	3	
14	3312 308 037	500028	. Vite di guida	. Guide bolt	1	
15	3312 308 047	500044	. Molla	. Spring	1	
16	0635 460 014	106695	. Sfera	. Ball	2	
17	3312 308 029	455764	. Interruttore completo	. Neutral safety switch assy.	1	
18	001.105.0158	105527	. Guarnizione OR	. O-Ring	1	
19	3312 308 039	500030	. Boccia	. Bushing	1	
20	0630 502 005	500083	. Anello elastico	. Snap ring	1	
21	3312 308 038	500029	. Boccia	. Bushing	1	
22	3312 308 042	500032	. Molla per lubrificazione	. Spring	1	
23	0635 460 023	500097	. Sfera	. Ball	1	
24	3312 308 036	500027	. Distanziale	. Spacer	1	

ZF 80 IV versions 029 - 030 - 031 - 032 - 033
ZF 80-1 IV versions 034 - 035 - 036 - 037 - 038

OLD ELECTRIC SELECTOR VALVE ON/OFF 12V, 26 BAR

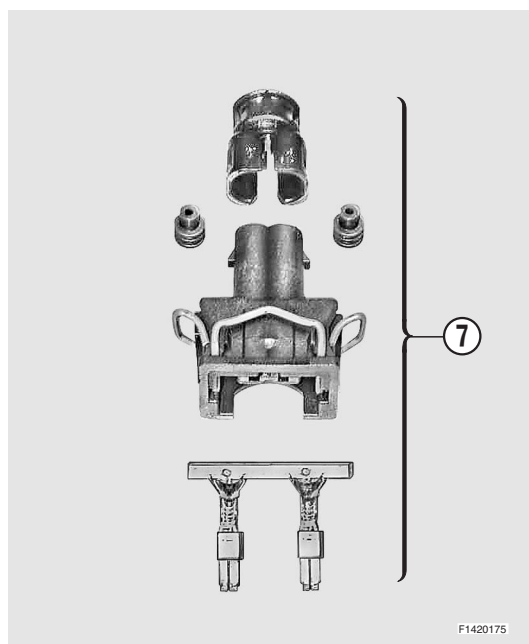
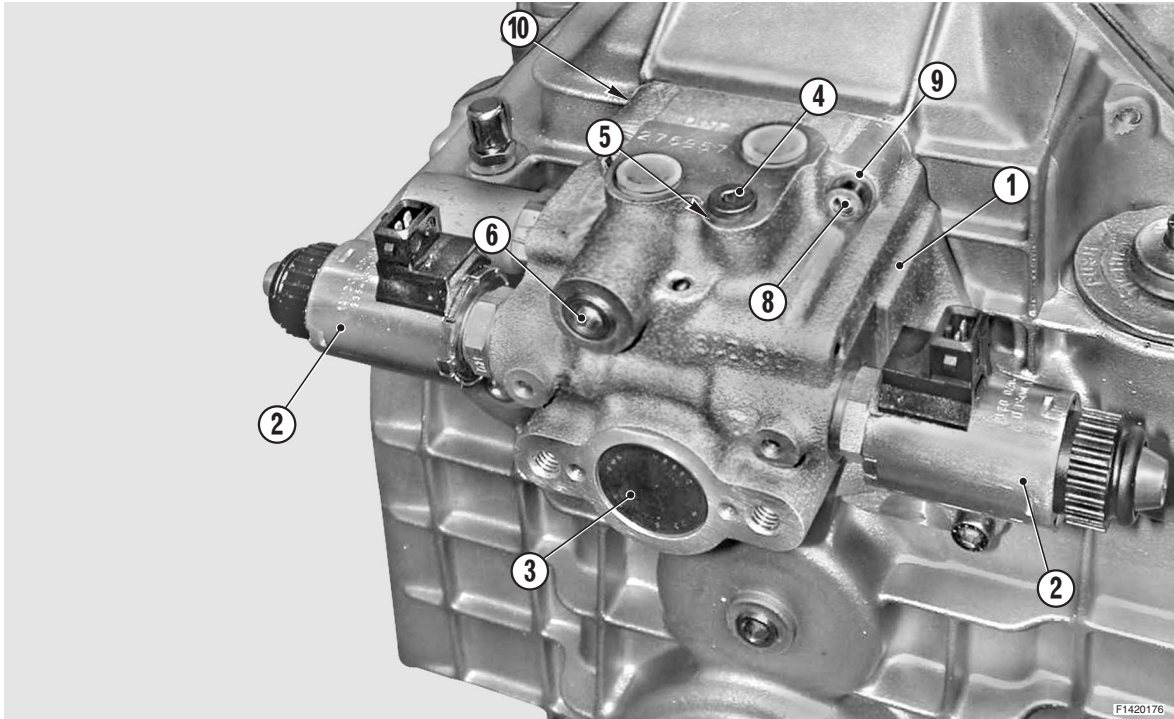



Pos.	Part number	Old P/N	Descrizione	Description	Q.tà Q.ty	Note
1	3312 199 015		Distributore elettrico 26 bar ON/OFF	Electric selector valve 26 bar ON/OFF	1	*
2	3312 308 069		Elettrovalvola ON/OFF 12V	Solenoid valve ON/OFF 12V	2	
3	0631 405 061		Tappo	Dummy plug	1	
4	0636 302 053		Tappo M10x1	Screw plug M10x1	1	Ma = 12 Nm
5	0634 801 302		Rosetta	Washer	1	
6	0636 309 007		Tappo	Screw plug	1	Ma = 30 Nm
7	3316 117 001		Assieme connettore	Connector kit	2	
8	0636 101 727		Vite T.E. M8x40	Cap screw M8x40	6	
9	0630 302 090		Rosetta	Spring washer	6	
10	3312 308 020		Guarnizione	Gasket	1	

* Installare con 12 V - *To be installed with 12 V power supply*

ZF 80 IV versions 029 - 030 - 031 - 032 - 033
ZF 80-1 IV versions 034 - 035 - 036 - 037 - 038

NEW ELECTRIC SELECTOR VALVE ON/OFF 12V - 26 BAR
NEW ELECTRIC SELECTOR VALVE ON/OFF 24V - 26 BAR

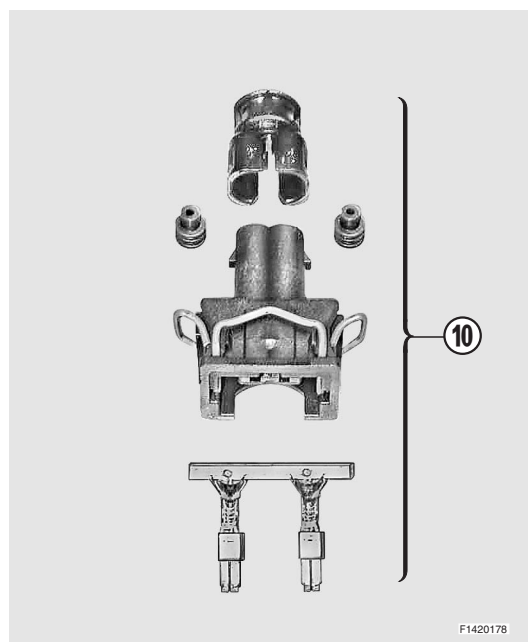
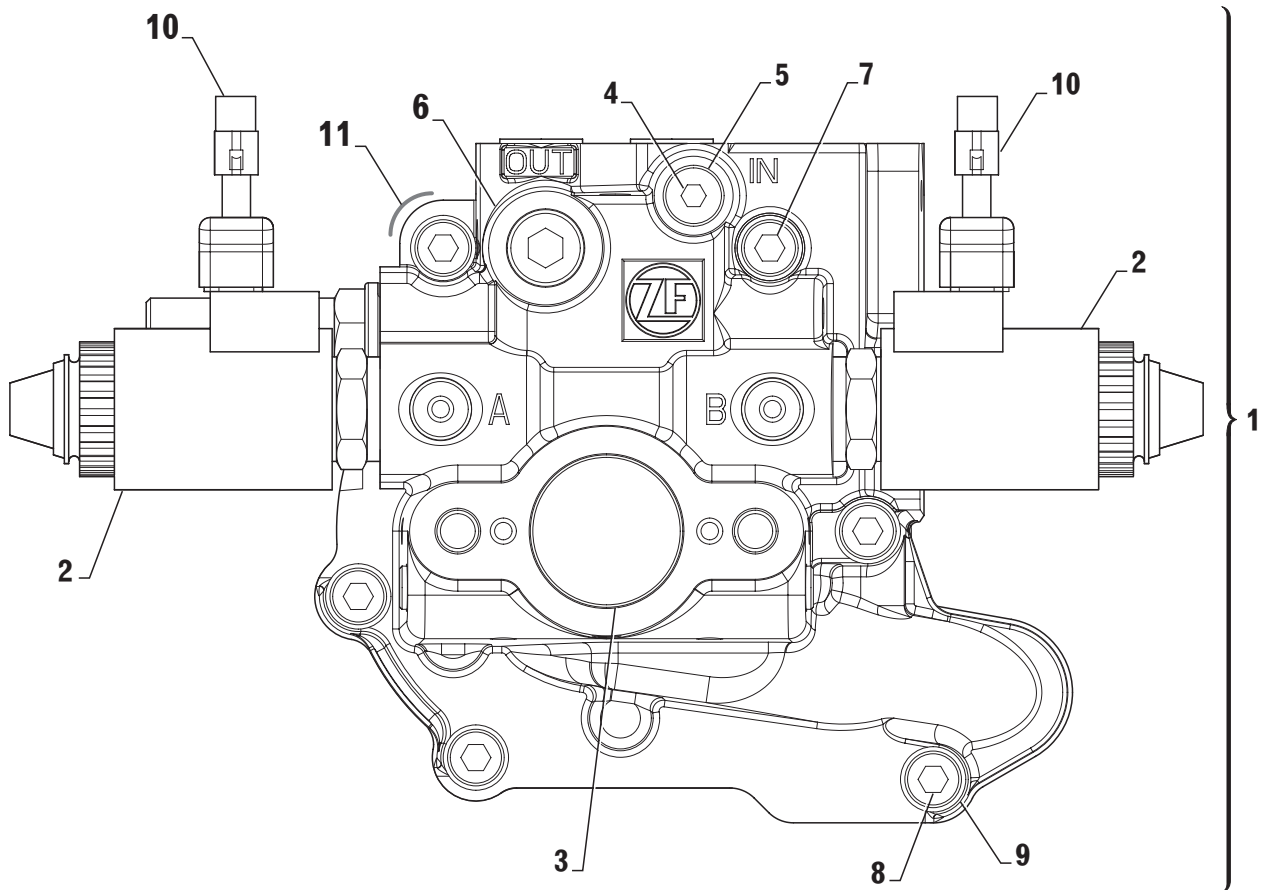



Pos.	Part number	Old P/N	Descrizione	Description	Q.tà Q.ty	Note
1	3312 199 063		Distributore elettrico ON/OFF 12V - 26 bar	Electric selector valve ON/OFF 12V - 26 bar	1	*
	3312 199 064		Distributore elettrico ON/OFF 24V - 26 bar	Electric selector valve ON/OFF 24V - 26 bar	1	* *
2	3312 308 069		Elettrovalvola ON/OFF 12V	Solenoid valve ON/OFF 12V	2	Ma = 20 Nm
	3312 308 106		Elettrovalvola ON/OFF 24V	Solenoid valve ON/OFF 24V	2	Ma = 20 Nm
3	0631 405 061		Tappo	Dummy plug	1	
4	0636 302 053		Tappo M10x1	Screw plug M10x1	1	Ma = 12 Nm
5	0634 801 302		Rosetta	Washer	1	
6	0636 309 007		Tappo	Screw plug	1	Ma = 35 Nm
7	0636 101 709		Vite T.E. M8x65	Cap screw M8x65	2	
8	0636 101 727		Vite T.E. M8x40	Cap screw M8x40	4	
9	0630 302 090		Rosetta elastica	Spring washer	6	
10	3316 117 001		Assieme connettore	Connector kit	2	
11	3312 308 020		Guarnizione	Gasket	1	

* Installare con 12 V - *To be installed with 12 V power supply*

* * Installare con 24 V - *To be installed with 24 V power supply*



Per convertire la elettrovalvola da 12V a 24V sostituire solo il solenoide con il ricambio a cod. 3312 199 062.
To transform the solenoid valve from 12V to 24V it will be enough to replace only the solenoid - available loosen P/N 3312 199 062.

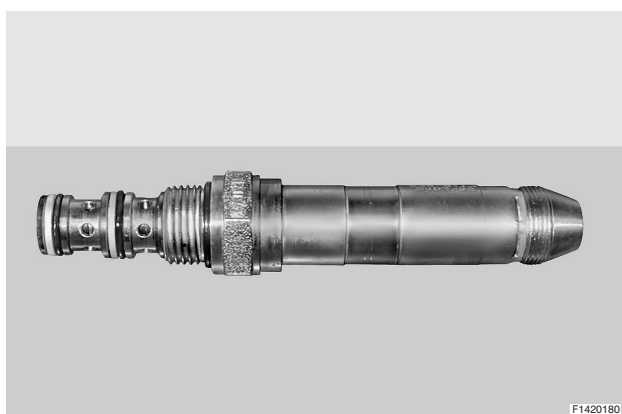

La valvola non è disponibile singolarmente ed è un componente comune alla versione 12V e 24V dell'elettrovalvola.
The valve is not available loosen and it is a common component both for 12V and 24V solenoid valve.

ZF 80 IV versions 029 - 030 - 031 - 032 - 033
ZF 80-1 IV versions 034 - 035 - 036 - 037 - 038

**NEW ELECTRIC SELECTOR VALVE ON/OFF 12V - 26 BAR
 WITH TROLLING VALVE**

**NEW ELECTRIC SELECTOR VALVE ON/OFF 24V - 26 BAR
 WITH TROLLING VALVE**

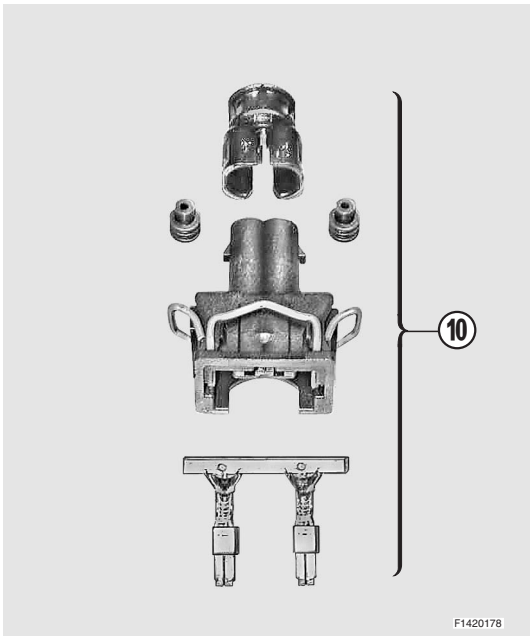
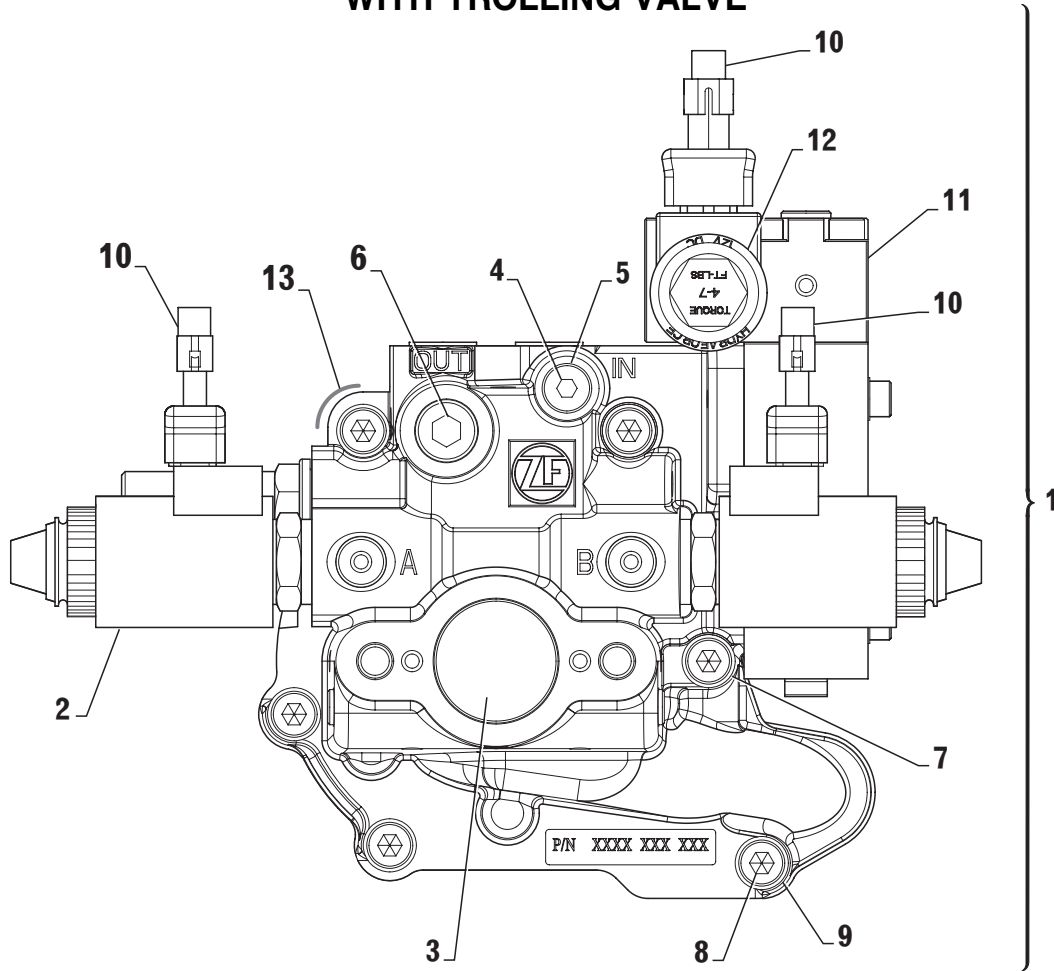

F1420178



Pos.	Part number	Old P/N	Descrizione	Description	Q.tà Q.ty	Note
1	3312 199 065		Distributore elettrico ON/OFF 12V, 26 bar con TV	Electric selector valve ON/OFF 12V, 26 bar with Trolling valve	1	*
	3312 199 066		Distributore elettrico ON/OFF 24V, 26 bar con TV	Electric selector valve ON/OFF 24V, 26 bar with Trolling valve	1	* *
2	3312 308 069		Elettrovalvola ON/OFF 12V, 26 BAR	Solenoid valve ON/OFF 12V, 26 bar	2	Ma = 20 Nm
	3312 308 106		Elettrovalvola ON/OFF 24V, 26 bar	Solenoid valve ON/OFF 24V, 26 bar	2	Ma = 20 Nm
3	0631 405 061		Tappo	Dummy plug	1	
4	0636 302 053		Tappo a vite M10x1	Screw plug M10x1	1	Ma = 12 Nm
5	0634 801 302		Anello di tenuta	Sealing ring	1	
6	0636 309 007		Tappo a vite	Screw plug	1	Ma = 35 Nm
7	0636 101 709		Vite TCEI M8x65	Cap screw M8x65	2	
8	0636 101 727		Vite TCEI M8x40	Cap screw M8x40	4	
9	0630 302 090		Rosetta elastica	Spring washer	6	
10	3316 117 001		Assieme connettore	Connector kit	3	
11	3312 108 027		Trolling valve	Trolling device	1	
12	3312 308 096		Valvola proporzionale 12V	Proportional valve 12V	1	Ma = 27 Nm
	3312 308 124		Valvola proporzionale 24V	Proportional valve 24V	1	Ma = 27 Nm
13	3312 308 020		Guarnizione	Gasket	1	

* Installare con 12 V - *To be installed with 12 V power supply*

* * Installare con 24 V - *To be installed with 24 V power supply*



Per convertire la elettrovalvola da 12V a 24V sostituire solo il solenoide con il ricambio a cod. 3312 199 062.
To transform the solenoid valve from 12V to 24V it will be enough to replace only the solenoid - available loosen P/N 3312 199 062.

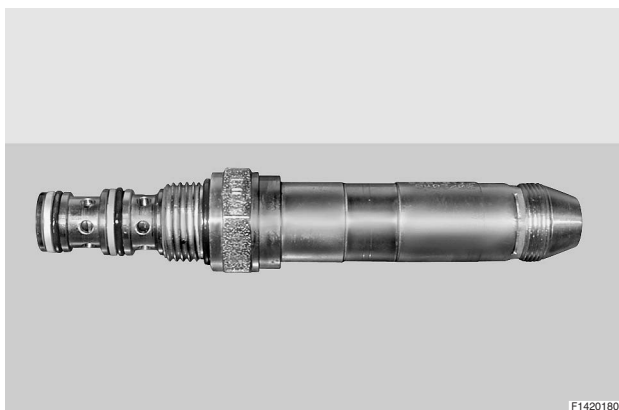

La valvola non è disponibile singolarmente ed è un componente comune alla versione 12V e 24V dell'elettrovalvola.
The valve is not available loosen and it is a common component both for 12V and 24V solenoid valve.

**COMPOSIZIONE KIT - KIT COMPONENTS****ZF 80 IV versions 029 - 030 - 031 - 032 - 033****ZF 80-1 IV versions 034 - 035 - 036 - 037 - 038**

Fig.	Pos.	Part number	Old P/N	Descrizione	Description	Q.ty
-	-	3313 199 023	500425	Kit guarnizioni e anelli elastici	Seal kit & piston rings	1
1	29	3312 301 030	413883	. Paraolio entrata	. Input shaft seal	1
1	5	0634 309 631	105113	. Paraolio uscita	. Output shaft seal	1
1	30	0634 309 619	480762	. Paraolio uscita	. Output shaft seal	1
3	3	3312 308 020	408388	. Guarnizione	. Gasket	1
3	8	0634 309 621	500065	. Anello di tenuta	. Seal	1
2	4	3312 302 041	447038	. Anello elastico	. Piston ring	3
1	23	0634 304 405	501211	. Guarnizione OR	. O-Ring	1
1	12	0634 304 688	442731	. Guarnizione OR	. O-Ring	1
1	13	0634 306 204	105542	. Guarnizione OR	. O-Ring	1
1	21	3312 301 008	439653	. Guarnizione	. Gasket	1
-	-	3313 199 079		Kit guarnizioni e frizioni	Seal kit & clutch kit	1
-	-	3313 199 023	500425	. Kit guarnizioni e anelli elastici	. Seal kit & piston rings	1
2	16	3319 302 006		. Disco frizione interno	. Inner clutch disc	8
2	15	3319 302 001		. Disco frizione esterno	. Outer clutch disc	10
-	-	3313 199 025	501219	Kit cuscinetti	Bearing kit	1
2	5,26	0635 501 937	447754	. Cuscinetto a rullini conici	. Tapered roller bearing	2
2	9	3312 302 040	441438	. Cuscinetto a rulli	. Needle bearing	4
2	24	0635 501 939	-	. Cuscinetto a rullini conici	. Tapered roller bearing	1
2	27	0635 501 938	333859	. Cuscinetto a rullini conici	. Tapered roller bearing	1
2	28	0635 374 005	229784	. Cuscinetto a rullini conici	. Tapered roller bearing	1
2	29	0635 372 007	106652	. Cuscinetto a rullini conici	. Tapered roller bearing	1
2	32	0635 370 017	464199	. Cuscinetto a rullini conici	. Tapered roller bearing	1
2	33	0635 373 010	480757	. Cuscinetto a rullini conici	. Tapered roller bearing	1
2	25	3313 302 042	439630	. Spessore 0,1 mm	. Shim 0.1 mm	2
2	25	3313 302 043	439631	. Spessore 0,15 mm	. Shim 0.15 mm	2
2	25	3313 302 044	439632	. Spessore 0,2 mm	. Shim 0.2 mm	2
2	25	3313 302 045	439633	. Spessore 0,5 mm	. Shim 0.5 mm	2
2	25	3313 302 046	439634	. Spessore 1,0 mm	. Shim 1.0 mm	2
2	30	3312 304 022	439393	. Spessore 0,1 mm	. Shim 0.1 mm	2
2	30	3312 304 023	439394	. Spessore 0,15 mm	. Shim 0.15 mm	2
2	30	3312 304 024	439395	. Spessore 0,3 mm	. Shim 0.3 mm	2
2	30	3312 304 025	439396	. Spessore 0,5 mm	. Shim 0.5 mm	2
2	31	3313 304 031	477560	. Spessore 0,1 mm	. Shim 0.1 mm	2
2	31	3313 304 030	477558	. Spessore 0,15 mm	. Shim 0.15 mm	2
2	31	3313 304 029	477557	. Spessore 0,2 mm	. Shim 0.2 mm	2
2	31	3313 304 028	447551	. Spessore 0,5 mm	. Shim 0.5 mm	2



13. SPARE PARTS LIST ZF 85 IV

Preface

The spare parts list is only valid for the type and versions of transmission, as shown below.

You will find the transmission type and version on your transmission name plate.

If the type and version indicated differs from that printed in this Manual, the relative Spare Parts List should be ordered from ZF HURTH MARINE.

The indicated dimensions and standards are as such not enough for ordering parts.

When ordering parts, please state:

- Transmission type
- Transmission version
- Serial number
- Item no.
- Part name
- Identification no.
- quantity of parts required.

The spare parts list is referring to the following versions:

ZF 85 IV versions 004 (1.64 R); 003 (2.01 R); 002 (2.49 R)

Name plate

The name plate is mounted to the transmission.

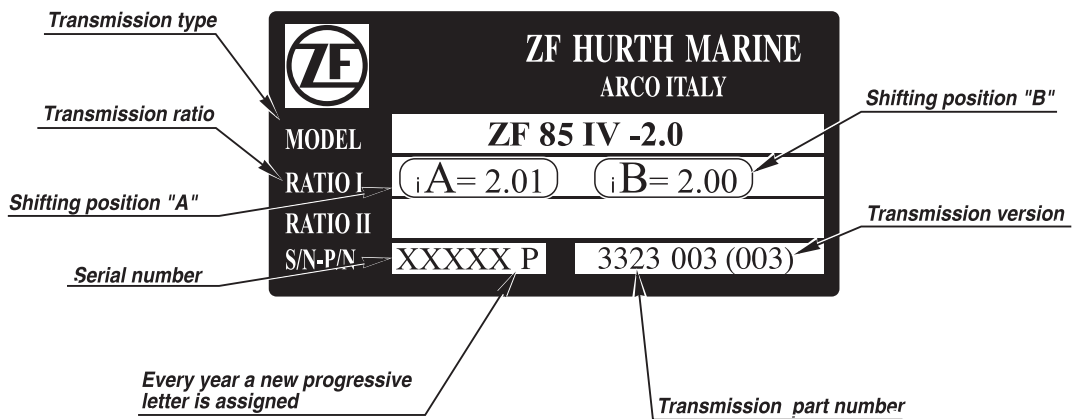

ZF 85 IV versions 002 - 003 - 004

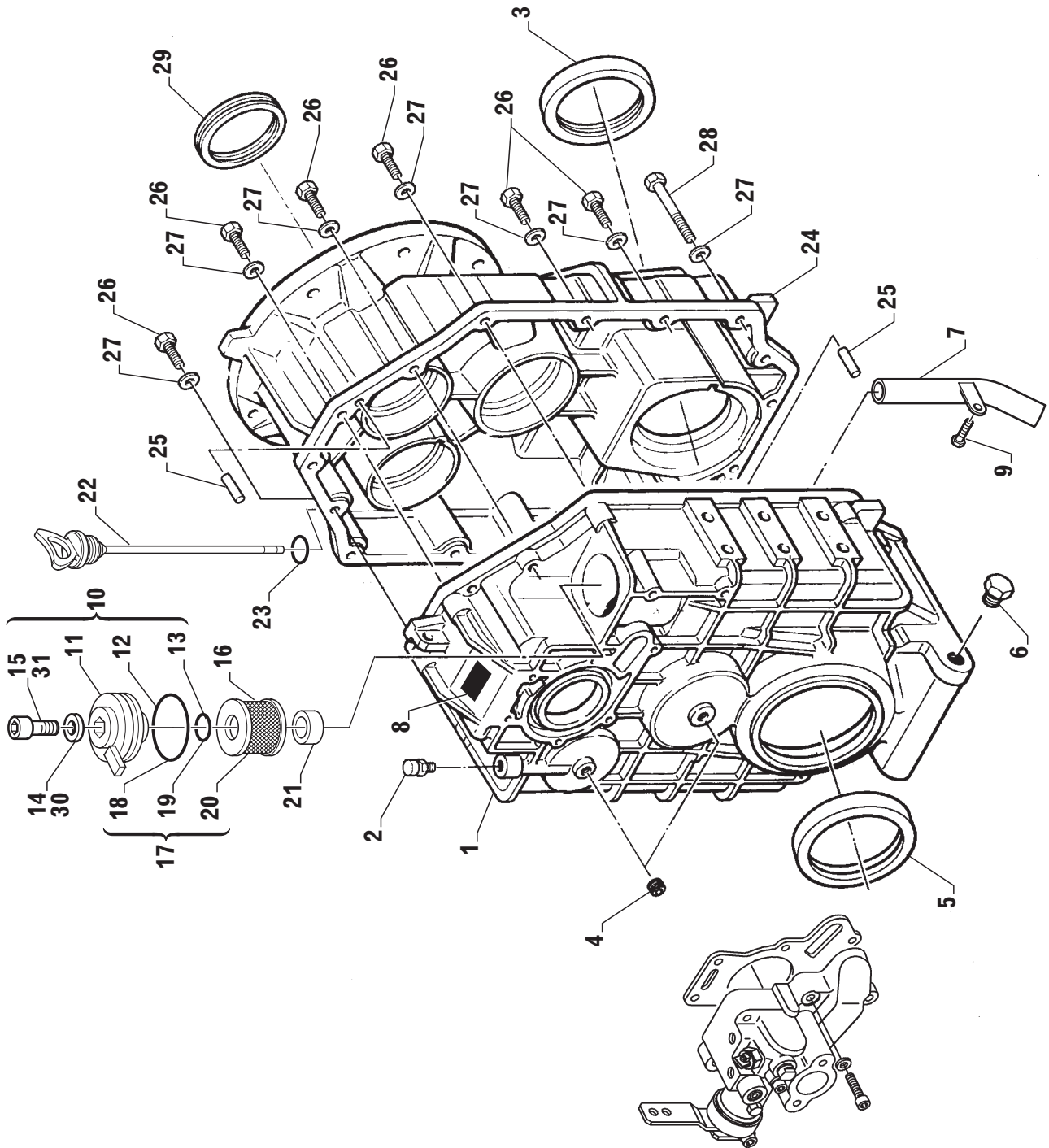



Pos.	Part number	Old P/N	Descrizione	Description	Q.tà Q.ty	Note
1	3323 199 002		Assieme scatola	Housing, assy.	1	
	3323 301 005		. Scatola	. Housing	1	
	3313 301 026		. Tubo aspirazione con supporto	. Suction pipe with support	1	
	0636 101 411		. Vite TCEI M6x16	. Cap screw M6x16	1	
	3312 301 008		. Guarnizione	. Gasket	1	
2	3311 301 002	442369	Valvola di sfiato	Breather valve	1	
3	0634 309 619	480762	Paraolio uscita	Output shaft seal	1	
4	0636 301 041	442373	Tappo a vite M16x1,5	Screw plug M16x1.5	2	
5	0634 309 631	105113	Paraolio uscita	Output shaft seal	1	
6	3312 301 017	469691	Tappo scarico olio	Oil drain plug	1	
7	3313 301 026		Tubo aspirazione con supporto	Suction pipe with support	1	
8	3312 301 001		Targhetta di identificazione	Name plate	1	
9	0636 101 411	102879	Vite T.E. M6x16 (fascetta tubo aspirazione)	Hex head screw M6x16 (suction pipe clamp)	1	
10	3312 101 003	500484	Coperchio filtro completo	Filter cover, assy.	1	
11	☆		. Coperchio filtro	. Filter cover	1	
12	0634 304 688	442731	. Guarnizione OR	. O-Ring	1	
13	0634 306 204	105542	. Guarnizione OR	. O-Ring	1	
14	0630 001 085	167010	. Rosetta	. Washer	1	
15	0636 101 475	320202	. Vite M8x30	. Screw M8x30	1	
16	3312 301 007	438637	Filtro olio	Oil filter	1	* old part number
17	3312 199 031	463772	Filtro olio completo	Oil filter, assy	1	
18	0634 304 688	442731	. Guarnizione OR	. O-Ring	1	
19	0634 306 204	105542	. Guarnizione OR	. O-Ring	1	
20	3312 301 037		. Filtro olio	. Oil filter	1	* new part number
21	3312 301 008	439653	Guarnizione	Gasket	1	
22	3313 201 002	500990	Asta livello olio + OR	Oil dipstick + OR	1	
23	0634 304 405	501211	. Guarnizione OR	. O-Ring	1	
24	3323 301 004	480425	Coperchio	Cover (housing)	1	
25	0631 315 520	335817	Spina	Locator pin	2	
26	0636 015 227	442375	Vite T.E. M10x35	Hex head screw M10x35	15	
27	0630 302 091	442371	Rosetta	Washer	16	
28	0636 010 463	315548	Vite T.E. M10x70	Hex head screw M10x70	1	
29	0634 301 846		Paraolio entrata	Input shaft seal	1	
30	0630 001 085	167010	Rosetta	Washer	1	
31	0636 101 475	320202	Vite M8x30	Screw M8x30	1	

* Fornito solamento incluso nel Kit filtro olio p/n 3312 199 031
Supplied only included in the oil filter Kit p/n 3312 199 031

ZF 85 IV versions 002 - 003 - 004

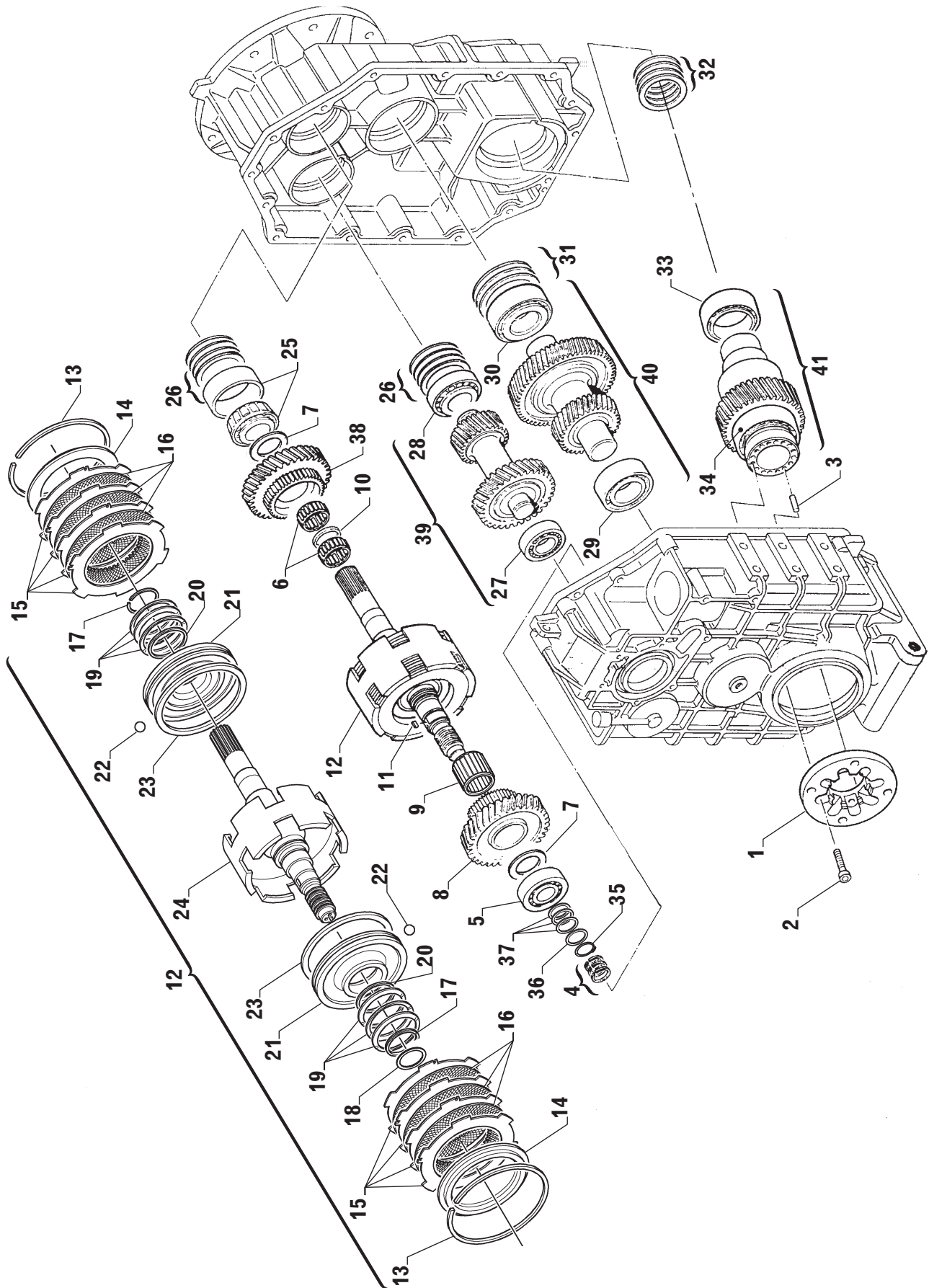



Pos.	Part number	Old P/N	Descrizione	Description	Q.tà Q.ty	Note
1	3313 304 019	480566	Flangia	Flange	1	
2	0636 101 072	312590	Vite TCEI M12x40	Cap screw M12x40	8	
3	0631 313 056	104661	Spina cilindrica 10x24	Locator pin 10x24	4	
4	3312 302 041	447038	Anello di tenuta	Piston ring	3	
5	0635 501 952		Cuscinetto a rulli conici	Tapered roller bearing	1	
6	0735 321 607		Cuscinetto a rullini	Needle bearing	2	
7	3323 302 008		Rasamento	Butting ring	2	
8	3323 302 023		Ingranaggio Z3 = 38	Reverse gear Z3 = 38	1	
9	0735 321 606		Cuscinetto a rullini	Needle bearing	1	
10	3323 302 013		Distanziale	Spacer	1	
11	0631 501 062	437956	Chiavetta	Key	1	
12	3323 199 004		Albero di ingresso completo	Input shaft, assy.	1	
13	0630 513 065		. Anello elastico	. Snap ring	2	
14	3323 302 017		. Disco finale	. End disc	2	
15	3323 302 012		. Disco frizione esterno	. Outer clutch disc	10	
16	3323 302 011		. Disco frizione interno	. Inner clutch disc	8	
17	3323 302 009		. Anello di ritegno	. Retainer ring	2	
18	3323 302 030		. Ralla	. Thrust washer	1	
19	3323 302 018		. Molla a tazza	. Cup spring	6	
20	0634 402 178	500066	. Anello interno	. Inner clutch piston ring	2	
21	3323 302 006		. Pistone	. Clutch piston	2	
22	0635 460 006	106690	. Sfera	. Ball	2	
23	0634 402 177		. Anello esterno	. Outer clutch piston ring	2	
24	3323 199 003		. Albero di ingresso + cilindro frizione	. Input shaft and clutch housing	1	
25	0635 501 951		Cuscinetto a rulli conici	Tapered roller bearing	1	
26	3313 302 042	439630	Spessore 0,1 mm	Shim 0.1 mm	2	
	3313 302 043	439631	Spessore 0,15 mm	Shim 0.15 mm	2	
	3313 302 044	439632	Spessore 0,2 mm	Shim 0.2 mm	2	
	3313 302 045	439633	Spessore 0,5 mm	Shim 0.5 mm	2	
	3313 302 046	439634	Spessore 1,0 mm	Shim 1.0 mm	2	
27	0635 501 937	447754	Cuscinetto a rulli conici	Tapered roller bearing	1	
28	0635 373 021	106664	Cuscinetto a rulli conici	Tapered roller bearing	1	
29	0635 374 005	229784	Cuscinetto a rulli conici	Tapered roller bearing	1	
30	0635 372 007	106652	Cuscinetto a rulli conici	Tapered roller bearing	1	
31	3312 304 022	439393	Spessore 0,1 mm	Shim 0.1 mm	2	
	3312 304 023	439394	Spessore 0,15 mm	Shim 0.15 mm	2	
	3312 304 024	439395	Spessore 0,3 mm	Shim 0.3 mm	2	
	3312 304 025	439396	Spessore 0,5 mm	Shim 0.5 mm	2	
32	3313 304 031	477560	Spessore 0,1 mm	Shim 0.1 mm	2	
	3313 304 030	477558	Spessore 0,15 mm	Shim 0.15 mm	2	
	3313 304 029	477557	Spessore 0,2 mm	Shim 0.2 mm	2	
	3313 304 028	477551	Spessore 0,5 mm	Shim 0.5 mm	2	
33	0635 370 017	464199	Cuscinetto a rulli conici	Tapered roller bearing	1	
34	0635 373 010	480757	Cuscinetto a rulli conici	Tapered roller bearing	1	
35	0630 501 031		Anello di sicurezza	Retaining ring	1	
36	0630 100 010		Disco appoggio	Support shim	1	
37	0630 000 193		Spessore 40x50x0,10	Shim 40x50x0.10	1	
	0630 000 298		Spessore 40x50x0,15	Shim 40x50x0.15	1	
	0630 000 274		Spessore 40x50x0,20	Shim 40x50x0.20	1	
Vers. 004 (Rapporto I = 1,64)				Vers. 004 (Ratio I = 1.64)		
38	3323 302 019		Ingranaggio Z1 = 33	Forward gear Z1 = 33	1	
39	3323 199 013		Albero intermedio Z4 = 39, Z5 = 34	Intermediate shaft Z4 = 39, Z5 = 34	1	*
40	3323 199 016		Albero intermedio Z2 = 46, Z6 = 39	Intermediate shaft Z2 = 46, Z6 = 39	1	*
41	3323 199 018		Albero uscita Z7 = 46	Output shaft Z7 = 46	1	*
Vers. 003 (Rapporto I = 2,01)				Vers. 003 (Ratio I = 2.01)		
38	3323 202 007		Ingranaggio Z1 = 31	Forward gear Z1 = 31	1	
39	3323 199 014		Albero intermedio Z4 = 39, Z5 = 32	Reversing shaft Z4 = 39, Z5 = 32	1	*
40	3323 199 025		Albero intermedio Z2 = 49, Z6 = 37	Intermediate shaft Z2 = 49, Z6 = 37	1	*
41	3323 199 026		Albero di uscita Z7 = 47	Output shaft Z7 = 47	1	*
Vers. 002 (Rapporto I = 2,49)				Vers. 002 (Ratio I = 2.49)		
38	3323 202 006		Ingranaggio Z1 = 27	Forward gear Z1 = 27	1	
39	3323 199 015		Albero intermedio Z4 = 39, Z5 = 28	Intermediate shaft Z4 = 39, Z5 = 28	1	*
40	3323 199 017		Albero intermedio Z2 = 53, Z6 = 37	Intermediate shaft Z2 = 53, Z6 = 37	1	*
41	3323 199 027		Albero di uscita Z7 = 47	Output shaft Z7 = 47	1	*

* Cuscinetti a rulli conici già assemblati - *Tapered roller bearings already assembled*

ZF 85 IV versions 002 - 003 - 004

MECHANICAL SELECTOR VALVE

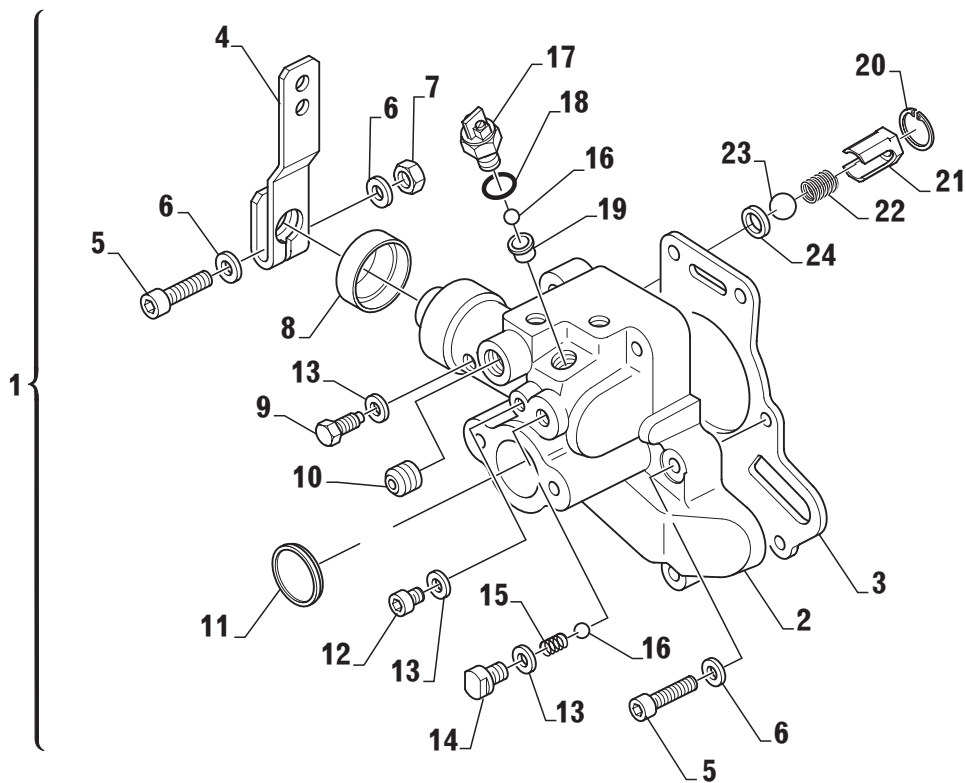



Pos.	Part number	Old P/N	Descrizione	Description	Q.tà Q.ty	Note
1	3313 108 001		Valvola di comando alta velocità	Mechanical selector valve 26 bar	1	
2	☆		. Valvola di comando	. Control valve	1	
3	3312 308 020	408388	. Guarnizione	. Gasket	1	
4	3312 308 025	452963	. Leva	. Lever	1	
5	0636 101 727	442377	. Vite T.E.	. Hex head screw	7	
6	0630 302 090	442372	. Rosetta	. Washer	8	
7	0637 006 157	455785	. Dado	. Nut	1	
8	0634 309 621	500065	. Guarnizione	. Gasket	1	
9	3312 308 034	500026	. Vite di fermo	. Stop screw	1	
10	0636 309 007	455756	. Tappo	. Plug	1	
11	0631 405 061	500107	. Tappo	. Plug	1	
12	0636 302 053	103465	. Tappo	. Plug	1	
13	0634 801 302	107410	. Rosetta	. Washer	3	
14	3312 308 037	500028	. Vite di guida	. Guide bolt	1	
15	3312 308 047	500044	. Molla	. Spring	1	
16	0635 460 014	106695	. Sfera	. Ball	2	
17	3312 308 029	455764	. Interruttore completo	. Neutral safety switch assy.	1	
18	001.105.0158	105527	. Guarnizione OR	. O-Ring	1	
19	3312 308 039	500030	. Boccia	. Bushing	1	
20	0630 502 005	500083	. Anello elastico	. Snap ring	1	
21	3312 308 038	500029	. Boccia	. Bushing	1	
22	3312 308 042	500032	. Molla per lubrificazione	. Spring	1	
23	0635 460 023	500097	. Sfera	. Ball	1	
24	3312 308 036	500027	. Distanziale	. Spacer	1	

ZF 85 IV versions 002 - 003 - 004

ELECTRIC SELECTOR VALVE ON/OFF 12V - 26 BAR

ELECTRIC SELECTOR VALVE ON/OFF 24V - 26 BAR

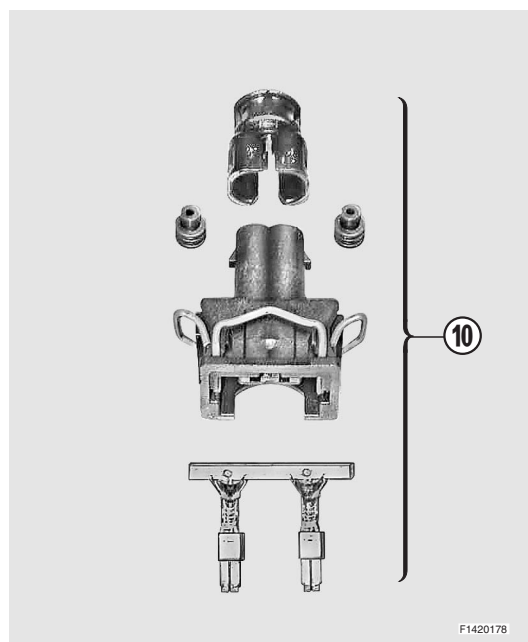
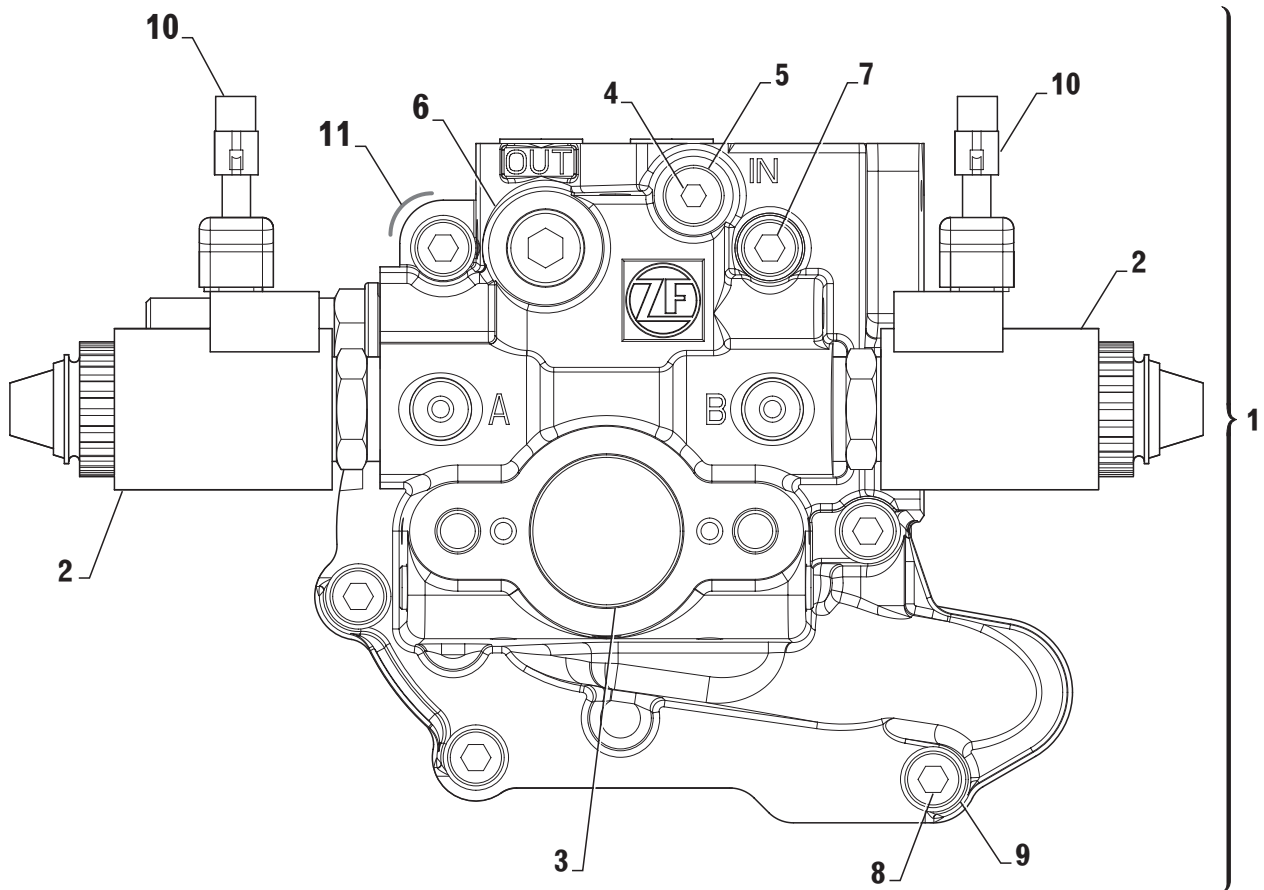



Pos.	Part number	Old P/N	Descrizione	Description	Q.tà Q.ty	Note
1	3312 199 063		Distributore elettrico ON/OFF 12V - 26 bar	Electric selector valve ON/OFF 12V - 26 bar	1	*
	3312 199 064		Distributore elettrico ON/OFF 24V - 26 bar	Electric selector valve ON/OFF 24V - 26 bar	1	* *
2	3312 308 069		Elettrovalvola ON/OFF 12V	Solenoid valve ON/OFF 12V	2	Ma = 20 Nm
	3312 308 106		Elettrovalvola ON/OFF 24V	Solenoid valve ON/OFF 24V	2	Ma = 20 Nm
3	0631 405 061		Tappo	Dummy plug	1	
4	0636 302 053		Tappo M10x1	Screw plug M10x1	1	Ma = 12 Nm
5	0634 801 302		Rosetta	Washer	1	
6	0636 309 007		Tappo	Screw plug	1	Ma = 35 Nm
7	0636 101 709		Vite T.E. M8x65	Cap screw M8x65	2	
8	0636 101 727		Vite T.E. M8x40	Cap screw M8x40	4	
9	0630 302 090		Rosetta elastica	Spring washer	6	
10	3316 117 001		Assieme connettore	Connector kit	2	
11	3312 308 020		Guarnizione	Gasket	1	

* Installare con 12 V - *To be installed with 12 V power supply*

* * Installare con 24 V - *To be installed with 24 V power supply*



Per convertire la elettrovalvola da 12V a 24V sostituire solo il solenoide con il ricambio a cod. 3312 199 062.
To transform the solenoid valve from 12V to 24V it will be enough to replace only the solenoid - available loosen P/N 3312 199 062.

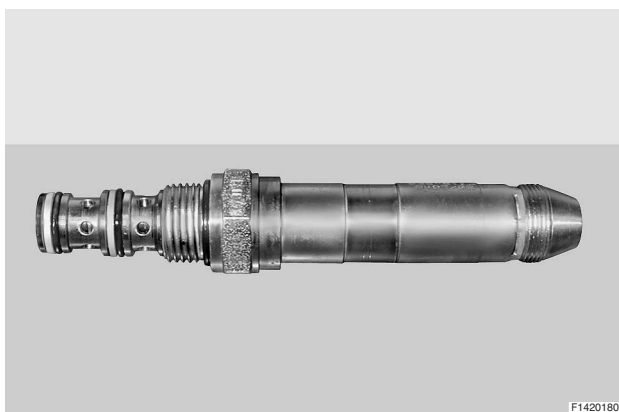

La valvola non è disponibile singolarmente ed è un componente comune alla versione 12V e 24V dell'elettrovalvola.
The valve is not available loosen and it is a common component both for 12V and 24V solenoid valve.

ZF 85 IV versions 002 - 003 - 004

**ELECTRIC SELECTOR VALVE ON/OFF 12V - 26 BAR
WITH TROLLING VALVE**

**ELECTRIC SELECTOR VALVE ON/OFF 24V - 26 BAR
WITH TROLLING VALVE**

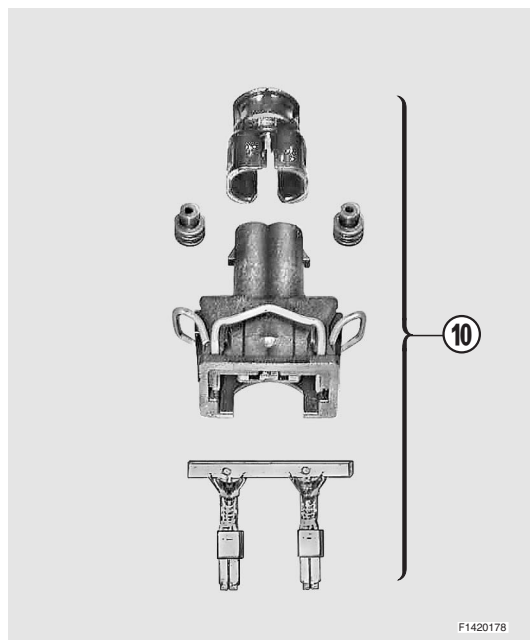
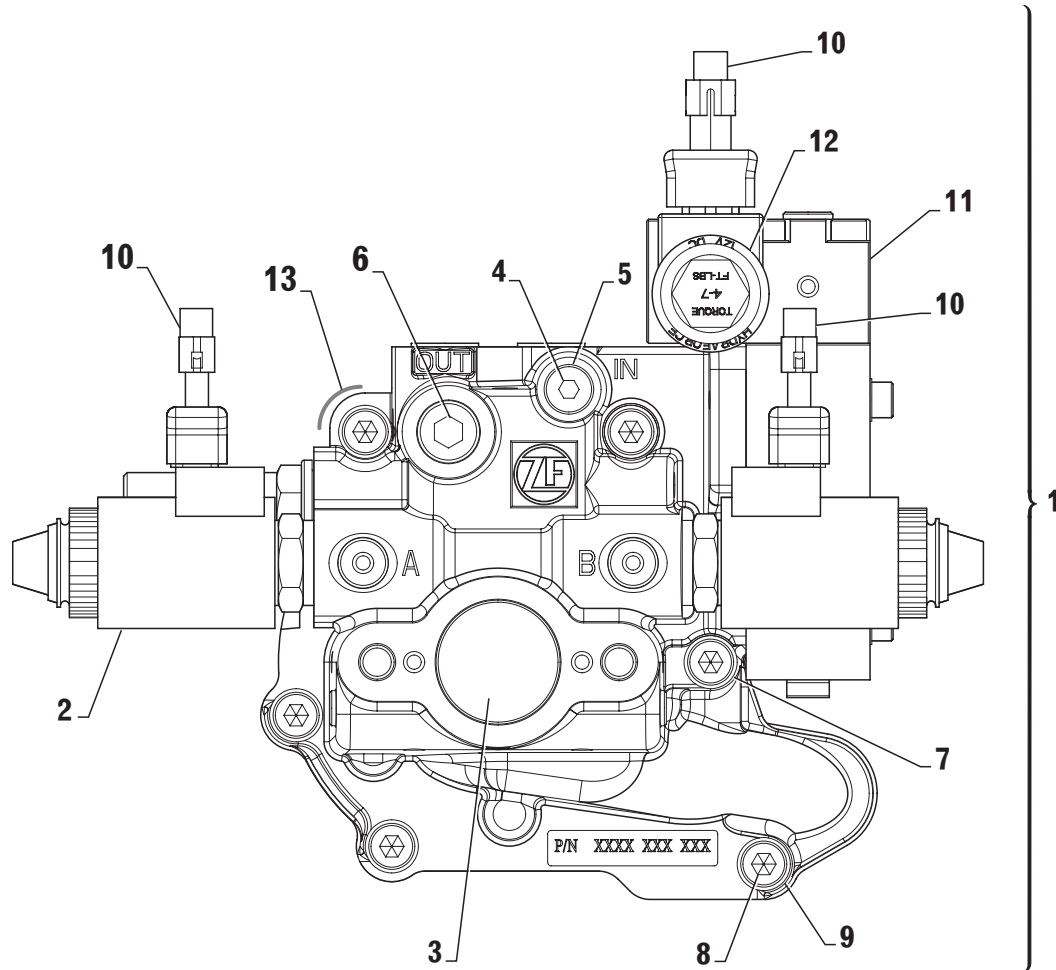



Pos.	Part number	Old P/N	Descrizione	Description	Q.tà Q.ty	Note
1	3312 199 065		Distributore elettrico ON/OFF 12V, 26 bar con TV	Electric selector valve ON/OFF 12V, 26 bar with Trolling valve	1	*
	3312 199 066		Distributore elettrico ON/OFF 24V, 26 bar con TV	Electric selector valve ON/OFF 24V, 26 bar with Trolling valve	1	* *
2	3312 308 069		Elettrovalvola ON/OFF 12V, 26 BAR	Solenoid valve ON/OFF 12V, 26 bar	2	Ma = 20 Nm
	3312 308 106		Elettrovalvola ON/OFF 24V, 26 bar	Solenoid valve ON/OFF 24V, 26 bar	2	Ma = 20 Nm
3	0631 405 061		Tappo	Dummy plug	1	
4	0636 302 053		Tappo a vite M10x1	Screw plug M10x1	1	Ma = 12 Nm
5	0634 801 302		Anello di tenuta	Sealing ring	1	
6	0636 309 007		Tappo a vite	Screw plug	1	Ma = 35 Nm
7	0636 101 709		Vite TCEI M8x65	Cap screw M8x65	2	
8	0636 101 727		Vite TCEI M8x40	Cap screw M8x40	4	
9	0630 302 090		Rosetta elastica	Spring washer	6	
10	3316 117 001		Assieme connettore	Connector kit	3	
11	3312 108 027		Trolling valve	Trolling device	1	
12	3312 308 096		Valvola proporzionale 12V	Proportional valve 12V	1	Ma = 27 Nm
	3312 308 124		Valvola proporzionale 24V	Proportional valve 24V	1	Ma = 27 Nm
13	3312 308 020		Guarnizione	Gasket	1	

* Installare con 12 V - *To be installed with 12 V power supply*

* * Installare con 24 V - *To be installed with 24 V power supply*



Per convertire la elettrovalvola da 12V a 24V sostituire solo il solenoide con il ricambio a cod. 3312 199 062.
To transform the solenoid valve from 12V to 24V it will be enough to replace only the solenoid - available loosen P/N 3312 199 062.

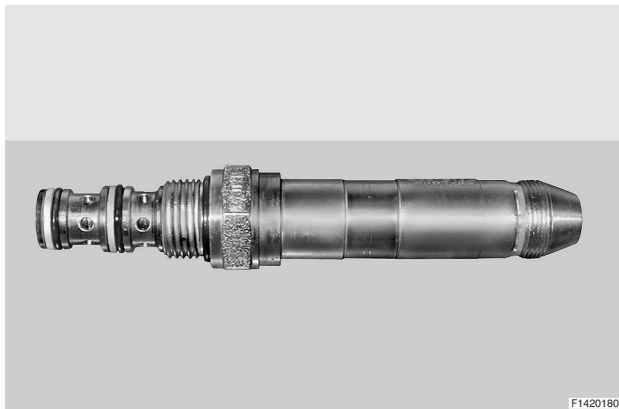

La valvola non è disponibile singolarmente ed è un componente comune alla versione 12V e 24V dell'elettrovalvola.
The valve is not available loosen and it is a common component both for 12V and 24V solenoid valve.

COMPOSIZIONE KIT - KIT COMPONENTS
ZF 85 IV versions 002 - 003 - 004

Fig.	Pos.	Part number	Old P/N	Descrizione	Description	Q.ty
-	-	3323 199 022		Kit guarnizioni e anelli elastici	Seal kit & piston rings	1
1	29	0634 301 846		. Paraolio entrata	. Input shaft seal	1
1	5	0634 309 631	105113	. Paraolio uscita	. Output shaft seal	1
1	3	0634 309 619	480762	. Paraolio uscita	. Output shaft seal	1
3	3	3312 308 020	408388	. Guarnizione	. Gasket	1
3	8	0634 309 621	500065	. Anello di tenuta	. Seal	1
2	4	3312 302 041	447038	. Anello elastico	. Piston ring	3
1	23	0634 304 405	501211	. Guarnizione OR	. O-Ring	1
1	12	0634 304 688	442731	. Guarnizione OR	. O-Ring	1
1	13	0634 306 204	105542	. Guarnizione OR	. O-Ring	1
1	21	3312 301 008	439653	. Guarnizione	. Gasket	1
-	-	3323 199 023		Kit guarnizioni e frizioni	Seal kit & clutch kit	1
-	-	3323 199 022		. Kit guarnizioni e anelli elastici	. Seal kit & piston rings	1
2	16	3323 302 011		. Disco frizione interno	. Inner clutch disc	8
2	15	3323 302 012		. Disco frizione esterno	. Outer clutch disc	10
-	-	3323 199 024		Kit cuscinetti	Bearing kit	1
2	5	0635 501 952	447754	. Cuscinetto a rullini conici	. Tapered roller bearing	1
2	6	0735 321 607		. Cuscinetto a rulli	. Needle bearing	2
2	9	0735 321 606		. Cuscinetto a rulli	. Needle bearing	1
2	25	0635 501 951	-	. Cuscinetto a rullini conici	. Tapered roller bearing	1
2	27	0635 501 937	447754	. Cuscinetto a rullini conici	. Tapered roller bearing	1
2	28	0635 501 938	333859	. Cuscinetto a rullini conici	. Tapered roller bearing	1
2	29	0635 374 005	229784	. Cuscinetto a rullini conici	. Tapered roller bearing	1
2	30	0635 372 007	106652	. Cuscinetto a rullini conici	. Tapered roller bearing	1
2	33	0635 370 017	464199	. Cuscinetto a rullini conici	. Tapered roller bearing	1
2	34	0635 373 010	480757	. Cuscinetto a rullini conici	. Tapered roller bearing	1
2	26	3313 302 042	439630	. Spessore 0,1 mm	. Shim 0.1 mm	2
2	26	3313 302 043	439631	. Spessore 0,15 mm	. Shim 0.15 mm	2
2	26	3313 302 044	439632	. Spessore 0,2 mm	. Shim 0.2 mm	2
2	26	3313 302 045	439633	. Spessore 0,5 mm	. Shim 0.5 mm	2
2	26	3313 302 046	439634	. Spessore 1,0 mm	. Shim 1.0 mm	2
2	31	3312 304 022	439393	. Spessore 0,1 mm	. Shim 0.1 mm	2
2	31	3312 304 023	439394	. Spessore 0,15 mm	. Shim 0.15 mm	2
2	31	3312 304 024	439395	. Spessore 0,3 mm	. Shim 0.3 mm	2
2	31	3312 304 025	439396	. Spessore 0,5 mm	. Shim 0.5 mm	2
2	32	3313 304 031	477560	. Spessore 0,1 mm	. Shim 0.1 mm	2
2	32	3313 304 030	477558	. Spessore 0,15 mm	. Shim 0.15 mm	2
2	32	3313 304 029	477557	. Spessore 0,2 mm	. Shim 0.2 mm	2
2	32	3313 304 028	447551	. Spessore 0,5 mm	. Shim 0.5 mm	2
2	37	0630 000 193		. Spessore 40x50x0,10	. Shim 40x50x0.10	1
2	37	0630 000 298		. Spessore 40x50x0,15	. Shim 40x50x0.15	1
2	37	0630 000 274		. Spessore 40x50x0,20	. Shim 40x50x0.20	1



14. SPARE PARTS LIST ZF 80 IV (ZF 85 IV DERIVATE VERSION)

Preface

The spare parts list is only valid for the type and versions of transmission, as shown below.

You will find the transmission type and version on your transmission name plate.

If the type and version indicated differs from that printed in this Manual, the relative Spare Parts List should be ordered from ZF HURTH MARINE.

The indicated dimensions and standards are as such not enough for ordering parts.

When ordering parts, please state:

- Transmission type
- Transmission version
- Serial number
- Item no.
- Part name
- Identification no.
- quantity of parts required.

The spare parts list is referring to the following versions:

ZF 80 IV versions 048 (1.64 R); 049 (2.01 R); 050 (2.49 R)

Name plate

The name plate is mounted to the transmission.

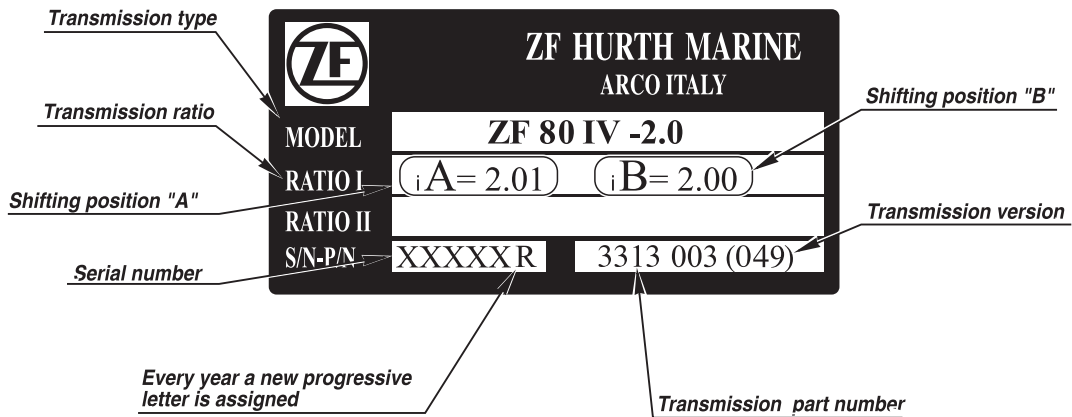

ZF 80 IV versions 048 - 049 - 050

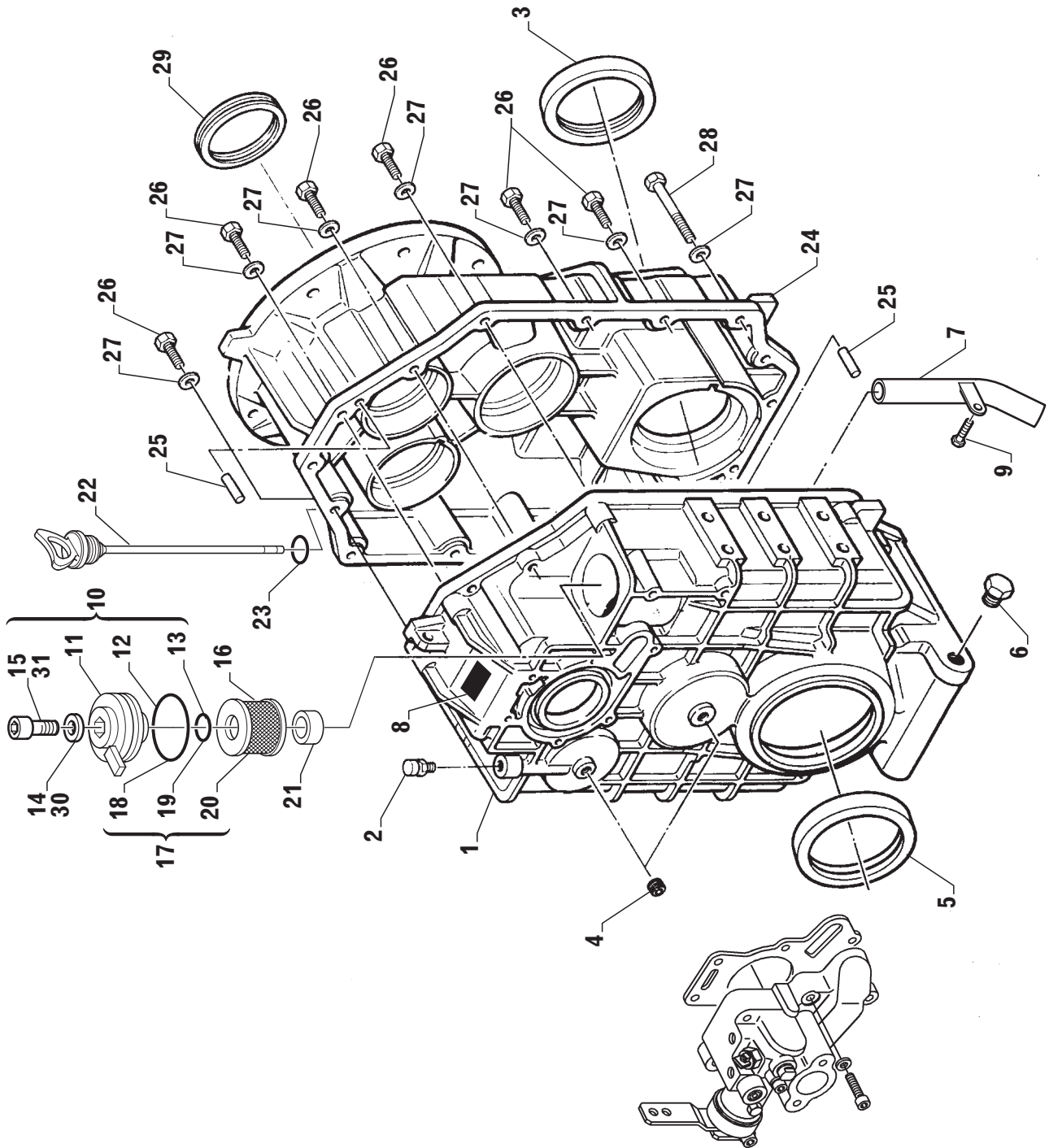



Pos.	Part number	Old P/N	Descrizione	Description	Q.tà Q.ty	Note
1	3323 199 002		Assieme scatola	Housing, assy.	1	
	3323 301 005		. Scatola	. Housing	1	
	3313 301 026		. Tubo aspirazione con supporto	. Suction pipe with support	1	
	0636 101 411		. Vite TCEI M6x16	. Cap screw M6x16	1	
	3312 301 008		. Guarnizione	. Gasket	1	
2	3311 301 002	442369	Valvola di sfiato	Breather valve	1	
3	0634 309 619	480762	Paraolio uscita	Output shaft seal	1	
4	0636 301 041	442373	Tappo a vite M16x1,5	Screw plug M16x1.5	2	
5	0634 309 631	105113	Paraolio uscita	Output shaft seal	1	
6	3312 301 017	469691	Tappo scarico olio	Oil drain plug	1	
7	3313 301 026		Tubo aspirazione con supporto	Suction pipe with support	1	
8	3312 301 001		Targhetta di identificazione	Name plate	1	
9	0636 101 411	102879	Vite T.E. M6x16 (fascetta tubo aspirazione)	Hex head screw M6x16 (suction pipe clamp)	1	
10	3312 101 003	500484	Coperchio filtro completo	Filter cover, assy.	1	
11	☆		. Coperchio filtro	. Filter cover	1	
12	0634 304 688	442731	. Guarnizione OR	. O-Ring	1	
13	0634 306 204	105542	. Guarnizione OR	. O-Ring	1	
14	0630 001 085	167010	. Rosetta	. Washer	1	
15	0636 101 475	320202	. Vite M8x30	. Screw M8x30	1	
16	3312 301 007	438637	Filtro olio	Oil filter	1	* old part number
17	3312 199 031	463772	Filtro olio completo	Oil filter, assy	1	
18	0634 304 688	442731	. Guarnizione OR	. O-Ring	1	
19	0634 306 204	105542	. Guarnizione OR	. O-Ring	1	
20	3312 301 037		. Filtro olio	. Oil filter	1	* new part number
21	3312 301 008	439653	Guarnizione	Gasket	1	
22	3313 201 002	500990	Asta livello olio + OR	Oil dipstick + OR	1	
23	0634 304 405	501211	. Guarnizione OR	. O-Ring	1	
24	3323 301 004	480425	Coperchio	Cover (housing)	1	
25	0631 315 520	335817	Spina	Locator pin	2	
26	0636 015 227	442375	Vite T.E. M10x35	Hex head screw M10x35	15	
27	0630 302 091	442371	Rosetta	Washer	16	
28	0636 010 463	315548	Vite T.E. M10x70	Hex head screw M10x70	1	
29	0634 301 846		Paraolio entrata	Input shaft seal	1	
30	0630 001 085	167010	Rosetta	Washer	1	
31	0636 101 475	320202	Vite M8x30	Screw M8x30	1	

* Fornito solamento incluso nel Kit filtro olio p/n 3312 199 031
Supplied only included in the oil filter Kit p/n 3312 199 031

ZF 80 IV versions 048 - 049 - 050

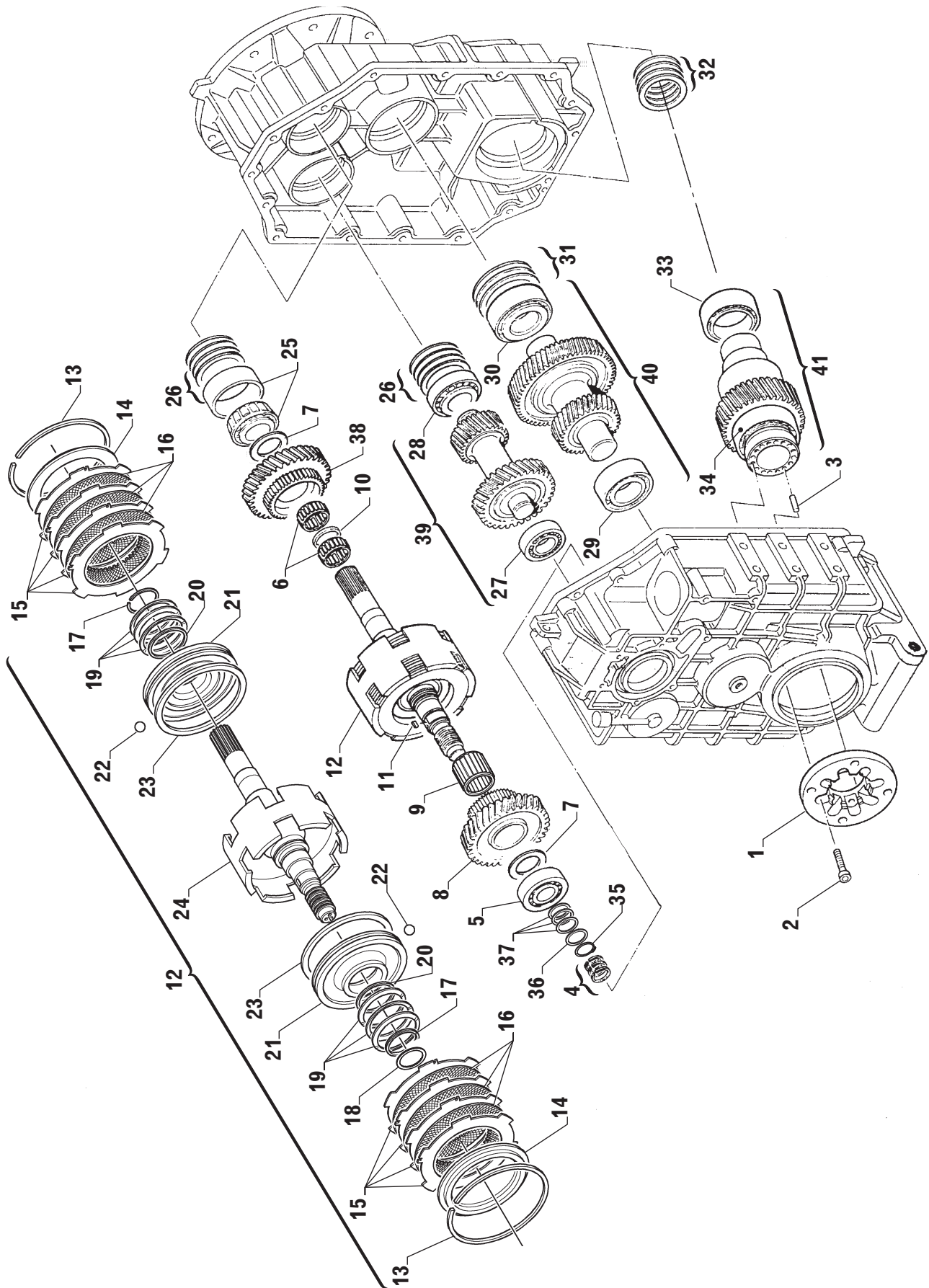



Pos.	Part number	Old P/N	Descrizione	Description	Q.tà Q.ty	Note
1	3313 304 019	480566	Flangia	Flange	1	
2	0636 101 072	312590	Vite TCEI M12x40	Cap screw M12x40	8	
3	0631 313 056	104661	Spina cilindrica 10x24	Locator pin 10x24	4	
4	3312 302 041	447038	Anello di tenuta	Piston ring	3	
5	0635 501 952		Cuscinetto a rulli conici	Tapered roller bearing	1	
6	0735 321 607		Cuscinetto a rullini	Needle bearing	2	
7	3323 302 008		Rasamento	Butting ring	2	
8	3313 302 064		Ingranaggio Z3 = 38	Reverse gear Z3 = 38	1	
9	0735 321 606		Cuscinetto a rullini	Needle bearing	1	
10	3323 302 013		Distanziale	Spacer	1	
11	0631 501 062	437956	Chiavetta	Key	1	
12	3313 199 109		Albero di ingresso completo	Input shaft, assy.	1	
13	0630 513 065		. Anello elastico	. Snap ring	2	
14	3323 302 017		. Disco finale	. End disc	2	
15	3323 302 012		. Disco frizione esterno	. Outer clutch disc	10	
16	3323 302 011		. Disco frizione interno	. Inner clutch disc	8	
17	3323 302 009		. Anello di ritegno	. Retainer ring	2	
18	3323 302 030		. Ralla	. Thrust washer	1	
19	3323 302 018		. Molla a tazza	. Cup spring	6	
20	0634 402 178	500066	. Anello interno	. Inner clutch piston ring	2	
21	3313 302 602		. Pistone	. Clutch piston	2	
22	0635 460 006	106690	. Sfera	. Ball	2	
23	0634 402 181		. Anello esterno	. Outer clutch piston ring	2	
24	3313 199 108		. Albero di ingresso + cilindro frizione	. Input shaft and clutch housing	1	
25	0635 501 951		Cuscinetto a rulli conici	Tapered roller bearing	1	
26	3313 302 042	439630	Spessore 0,1 mm	Shim 0.1 mm	2	
	3313 302 043	439631	Spessore 0,15 mm	Shim 0.15 mm	2	
	3313 302 044	439632	Spessore 0,2 mm	Shim 0.2 mm	2	
	3313 302 045	439633	Spessore 0,5 mm	Shim 0.5 mm	2	
	3313 302 046	439634	Spessore 1,0 mm	Shim 1.0 mm	2	
27	0635 501 937	447754	Cuscinetto a rulli conici	Tapered roller bearing	1	
28	0635 373 021	106664	Cuscinetto a rulli conici	Tapered roller bearing	1	
29	0635 374 005	229784	Cuscinetto a rulli conici	Tapered roller bearing	1	
30	0635 372 007	106652	Cuscinetto a rulli conici	Tapered roller bearing	1	
31	3312 304 022	439393	Spessore 0,1 mm	Shim 0.1 mm	2	
	3312 304 023	439394	Spessore 0,15 mm	Shim 0.15 mm	2	
	3312 304 024	439395	Spessore 0,3 mm	Shim 0.3 mm	2	
	3312 304 025	439396	Spessore 0,5 mm	Shim 0.5 mm	2	
32	3313 304 031	477560	Spessore 0,1 mm	Shim 0.1 mm	2	
	3313 304 030	477558	Spessore 0,15 mm	Shim 0.15 mm	2	
	3313 304 029	477557	Spessore 0,2 mm	Shim 0.2 mm	2	
	3313 304 028	477551	Spessore 0,5 mm	Shim 0.5 mm	2	
33	0635 370 017	464199	Cuscinetto a rulli conici	Tapered roller bearing	1	
34	0635 373 010	480757	Cuscinetto a rulli conici	Tapered roller bearing	1	
35	0630 501 031		Anello di sicurezza	Retaining ring	1	
36	0630 100 010		Disco appoggio	Support shim	1	
37	0630 000 193		Spessore 40x50x0,10	Shim 40x50x0.10	1	
	0630 000 298		Spessore 40x50x0,15	Shim 40x50x0.15	1	
	0630 000 274		Spessore 40x50x0,20	Shim 40x50x0.20	1	
Vers. 048 (Rapporto I = 1,64)			Vers. 048 (Ratio I = 1.64)			
38	3323 302 019		Ingranaggio Z1 = 33	Forward gear Z1 = 33	1	
39	3323 199 013		Albero intermedio Z4 = 39, Z5 = 34	Intermediate shaft Z4 = 39, Z5 = 34	1	*
40	3323 199 016		Albero intermedio Z2 = 46, Z6 = 39	Intermediate shaft Z2 = 46, Z6 = 39	1	*
41	3323 199 018		Albero uscita Z7 = 46	Output shaft Z7 = 46	1	*
Vers. 049 (Rapporto I = 2,01)			Vers. 049 (Ratio I = 2.01)			
38	3323 202 007		Ingranaggio Z1 = 31	Forward gear Z1 = 31	1	
39	3323 199 014		Albero intermedio Z4 = 39, Z5 = 32	Reversing shaft Z4 = 39, Z5 = 32	1	*
40	3323 199 025		Albero intermedio Z2 = 49, Z6 = 37	Intermediate shaft Z2 = 49, Z6 = 37	1	*
41	3323 199 026		Albero di uscita Z7 = 47	Output shaft Z7 = 47	1	*
Vers. 050 (Rapporto I = 2,49)			Vers. 050 (Ratio I = 2.49)			
38	3313 202 022		Ingranaggio Z1 = 27	Forward gear Z1 = 27	1	
39	3323 199 015		Albero intermedio Z4 = 39, Z5 = 28	Intermediate shaft Z4 = 39, Z5 = 28	1	*
40	3313 199 115		Albero intermedio Z2 = 53, Z6 = 37	Intermediate shaft Z2 = 53, Z6 = 37	1	*
41	3323 199 027		Albero di uscita Z7 = 47	Output shaft Z7 = 47	1	*

* Cuscinetti a rulli conici già assemblati - *Tapered roller bearings already assembled*

ZF 80 IV versions 048 - 049 - 050

MECHANICAL SELECTOR VALVE

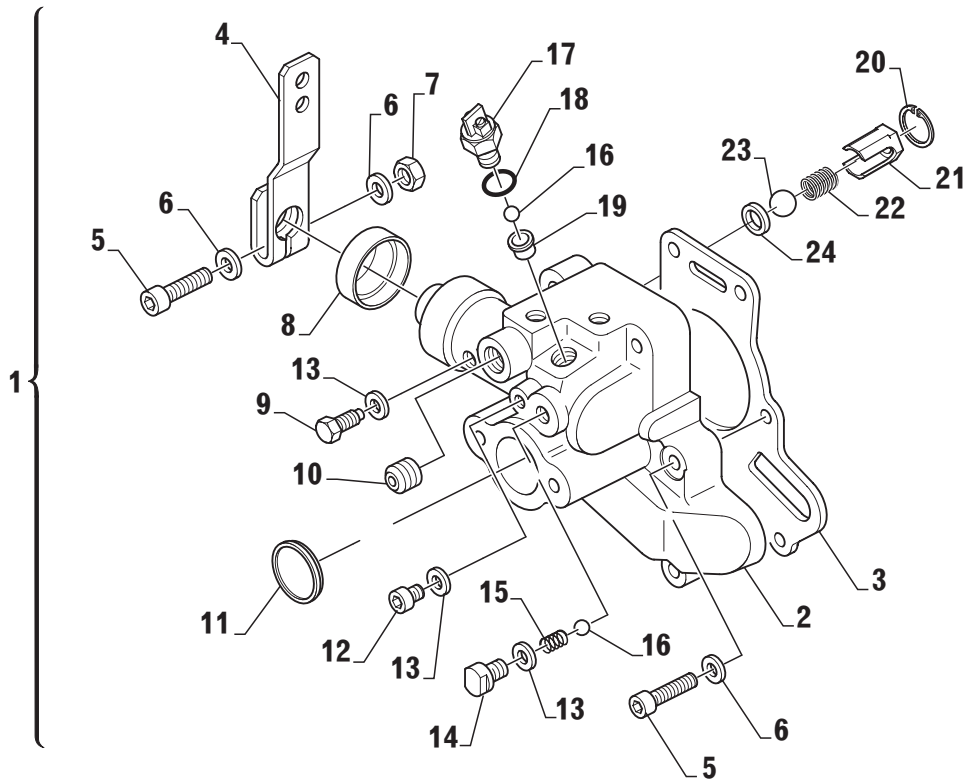



Pos.	Part number	Old P/N	Descrizione	Description	Q.tà Q.ty	Note
1	3313 108 001		Valvola di comando alta velocità	Mechanical selector valve 26 bar	1	
2	☆		. Valvola di comando	. Control valve	1	
3	3312 308 020	408388	. Guarnizione	. Gasket	1	
4	3312 308 025	452963	. Leva	. Lever	1	
5	0636 101 727	442377	. Vite T.E.	. Hex head screw	7	
6	0630 302 090	442372	. Rosetta	. Washer	8	
7	0637 006 157	455785	. Dado	. Nut	1	
8	0634 309 621	500065	. Guarnizione	. Gasket	1	
9	3312 308 034	500026	. Vite di fermo	. Stop screw	1	
10	0636 309 007	455756	. Tappo	. Plug	1	
11	0631 405 061	500107	. Tappo	. Plug	1	
12	0636 302 053	103465	. Tappo	. Plug	1	
13	0634 801 302	107410	. Rosetta	. Washer	3	
14	3312 308 037	500028	. Vite di guida	. Guide bolt	1	
15	3312 308 047	500044	. Molla	. Spring	1	
16	0635 460 014	106695	. Sfera	. Ball	2	
17	3312 308 029	455764	. Interruttore completo	. Neutral safety switch assy.	1	
18	001.105.0158	105527	. Guarnizione OR	. O-Ring	1	
19	3312 308 039	500030	. Boccia	. Bushing	1	
20	0630 502 005	500083	. Anello elastico	. Snap ring	1	
21	3312 308 038	500029	. Boccia	. Bushing	1	
22	3312 308 042	500032	. Molla per lubrificazione	. Spring	1	
23	0635 460 023	500097	. Sfera	. Ball	1	
24	3312 308 036	500027	. Distanziale	. Spacer	1	

ZF 80 IV versions 048 - 049 - 050

ELECTRIC SELECTOR VALVE ON/OFF 12V - 26 BAR

ELECTRIC SELECTOR VALVE ON/OFF 24V - 26 BAR

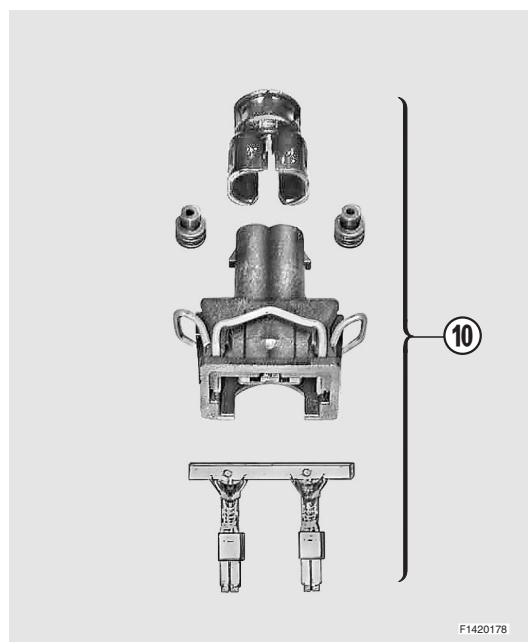
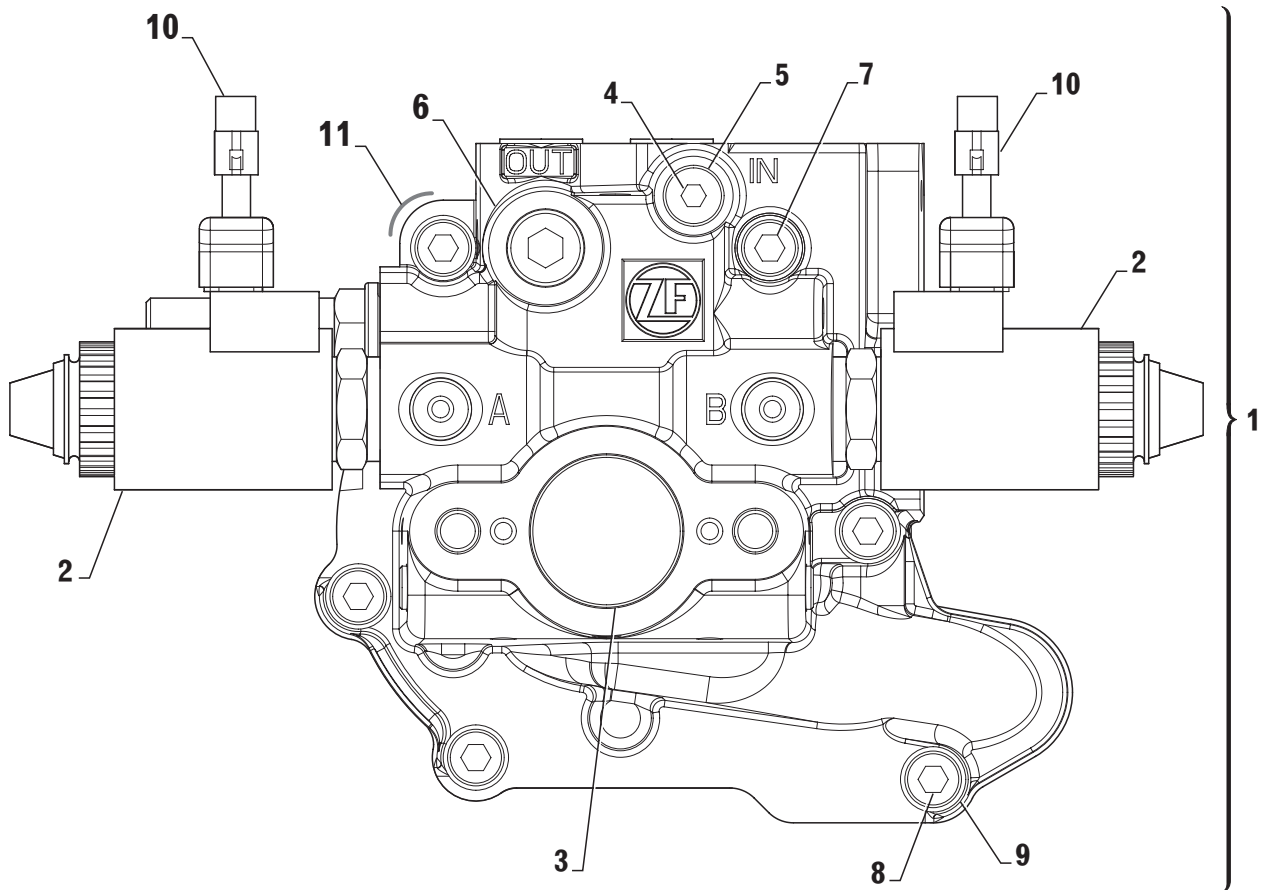

F1420178



Pos.	Part number	Old P/N	Descrizione	Description	Q.tà Q.ty	Note
1	3312 199 063		Distributore elettrico ON/OFF 12V - 26 bar	Electric selector valve ON/OFF 12V - 26 bar	1	*
	3312 199 064		Distributore elettrico ON/OFF 24V - 26 bar	Electric selector valve ON/OFF 24V - 26 bar	1	* *
2	3312 308 069		Elettrovalvola ON/OFF 12V	Solenoid valve ON/OFF 12V	2	Ma = 20 Nm
	3312 308 106		Elettrovalvola ON/OFF 24V	Solenoid valve ON/OFF 24V	2	Ma = 20 Nm
3	0631 405 061		Tappo	Dummy plug	1	
4	0636 302 053		Tappo M10x1	Screw plug M10x1	1	Ma = 12 Nm
5	0634 801 302		Rosetta	Washer	1	
6	0636 309 007		Tappo	Screw plug	1	Ma = 35 Nm
7	0636 101 709		Vite T.E. M8x65	Cap screw M8x65	2	
8	0636 101 727		Vite T.E. M8x40	Cap screw M8x40	4	
9	0630 302 090		Rosetta elastica	Spring washer	6	
10	3316 117 001		Assieme connettore	Connector kit	2	
11	3312 308 020		Guarnizione	Gasket	1	

* Installare con 12 V - *To be installed with 12 V power supply*

* * Installare con 24 V - *To be installed with 24 V power supply*



Per convertire la elettrovalvola da 12V a 24V sostituire solo il solenoide con il ricambio a cod. 3312 199 062.
To transform the solenoid valve from 12V to 24V it will be enough to replace only the solenoid - available loosen P/N 3312 199 062.

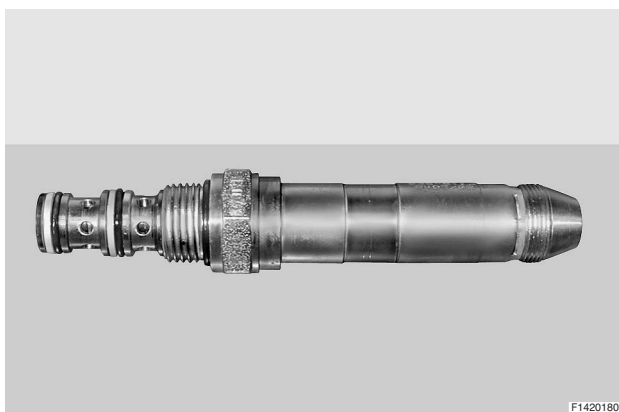

La valvola non è disponibile singolarmente ed è un componente comune alla versione 12V e 24V dell'elettrovalvola.
The valve is not available loosen and it is a common component both for 12V and 24V solenoid valve.

ZF 80 IV versions 048 - 049 - 050

**ELECTRIC SELECTOR VALVE ON/OFF 12V - 26 BAR
WITH TROLLING VALVE**

**ELECTRIC SELECTOR VALVE ON/OFF 24V - 26 BAR
WITH TROLLING VALVE**

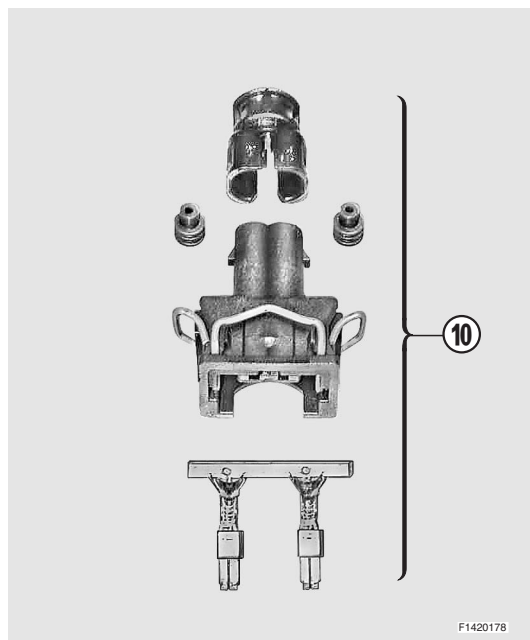
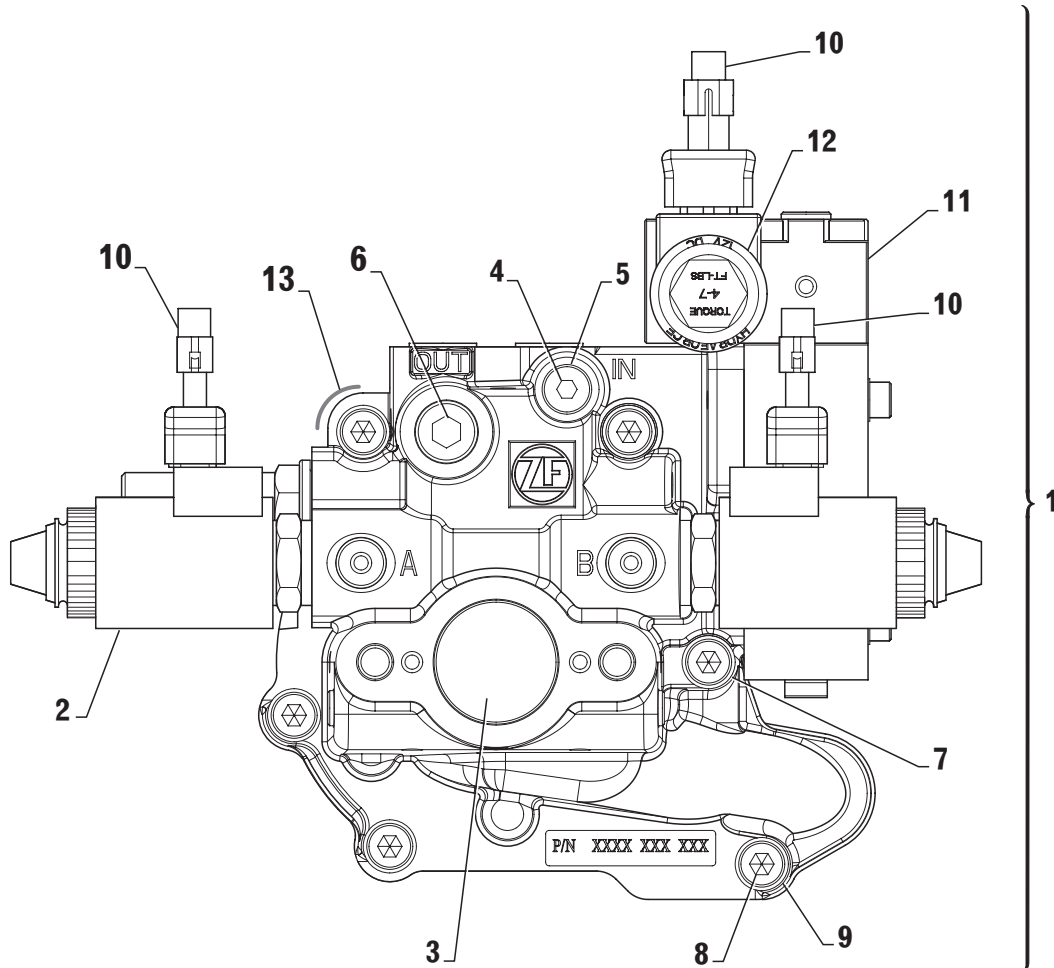



Pos.	Part number	Old P/N	Descrizione	Description	Q.tà Q.ty	Note
1	3312 199 065		Distributore elettrico ON/OFF 12V, 26 bar con TV	Electric selector valve ON/OFF 12V, 26 bar with Trolling valve	1	*
	3312 199 066		Distributore elettrico ON/OFF 24V, 26 bar con TV	Electric selector valve ON/OFF 24V, 26 bar with Trolling valve	1	* *
2	3312 308 069		Elettrovalvola ON/OFF 12V, 26 BAR	Solenoid valve ON/OFF 12V, 26 bar	2	Ma = 20 Nm
	3312 308 106		Elettrovalvola ON/OFF 24V, 26 bar	Solenoid valve ON/OFF 24V, 26 bar	2	Ma = 20 Nm
3	0631 405 061		Tappo	Dummy plug	1	
4	0636 302 053		Tappo a vite M10x1	Screw plug M10x1	1	Ma = 12 Nm
5	0634 801 302		Anello di tenuta	Sealing ring	1	
6	0636 309 007		Tappo a vite	Screw plug	1	Ma = 35 Nm
7	0636 101 709		Vite TCEI M8x65	Cap screw M8x65	2	
8	0636 101 727		Vite TCEI M8x40	Cap screw M8x40	4	
9	0630 302 090		Rosetta elastica	Spring washer	6	
10	3316 117 001		Assieme connettore	Connector kit	3	
11	3312 108 027		Trolling valve	Trolling device	1	
12	3312 308 096		Valvola proporzionale 12V	Proportional valve 12V	1	Ma = 27 Nm
	3312 308 124		Valvola proporzionale 24V	Proportional valve 24V	1	Ma = 27 Nm
13	3312 308 020		Guarnizione	Gasket	1	

* Installare con 12 V - *To be installed with 12 V power supply*

* * Installare con 24 V - *To be installed with 24 V power supply*



Per convertire la elettrovalvola da 12V a 24V sostituire solo il solenoide con il ricambio a cod. 3312 199 062.
To transform the solenoid valve from 12V to 24V it will be enough to replace only the solenoid - available loosen P/N 3312 199 062.

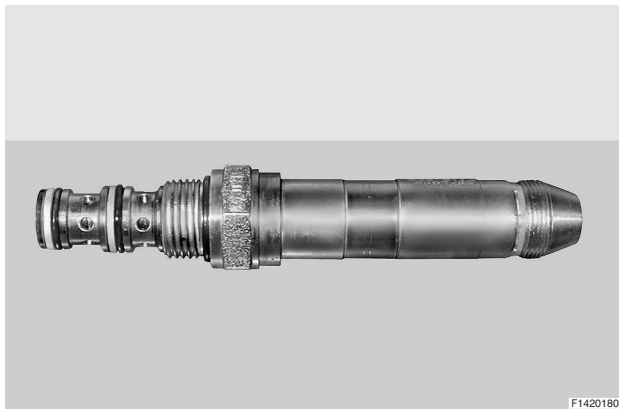

La valvola non è disponibile singolarmente ed è un componente comune alla versione 12V e 24V dell'elettrovalvola.
The valve is not available loosen and it is a common component both for 12V and 24V solenoid valve.

**COMPOSIZIONE KIT - KIT COMPONENTS****ZF 80 IV versions 048 - 049 - 050**

Fig.	Pos.	Part number	Old P/N	Descrizione	Description	Q.ty
-	-	3323 199 022		Kit guarnizioni e anelli elastici	Seal kit & piston rings	1
1	29	0634 301 846		. Paraolio entrata	. Input shaft seal	1
1	5	0634 309 631	105113	. Paraolio uscita	. Output shaft seal	1
1	3	0634 309 619	480762	. Paraolio uscita	. Output shaft seal	1
3	3	3312 308 020	408388	. Guarnizione	. Gasket	1
3	8	0634 309 621	500065	. Anello di tenuta	. Seal	1
2	4	3312 302 041	447038	. Anello elastico	. Piston ring	3
1	23	0634 304 405	501211	. Guarnizione OR	. O-Ring	1
1	12	0634 304 688	442731	. Guarnizione OR	. O-Ring	1
1	13	0634 306 204	105542	. Guarnizione OR	. O-Ring	1
1	21	3312 301 008	439653	. Guarnizione	. Gasket	1
-	-	3323 199 023		Kit guarnizioni e frizioni	Seal kit & clutch kit	1
-	-	3323 199 022		. Kit guarnizioni e anelli elastici	. Seal kit & piston rings	1
2	16	3323 302 011		. Disco frizione interno	. Inner clutch disc	8
2	15	3323 302 012		. Disco frizione esterno	. Outer clutch disc	10
-	-	3323 199 024		Kit cuscinetti	Bearing kit	1
2	5	0635 501 952	447754	. Cuscinetto a rullini conici	. Tapered roller bearing	1
2	6	0735 321 607		. Cuscinetto a rulli	. Needle bearing	2
2	9	0735 321 606		. Cuscinetto a rulli	. Needle bearing	1
2	25	0635 501 951	-	. Cuscinetto a rullini conici	. Tapered roller bearing	1
2	27	0635 501 937	447754	. Cuscinetto a rullini conici	. Tapered roller bearing	1
2	28	0635 501938	333859	. Cuscinetto a rullini conici	. Tapered roller bearing	1
2	29	0635 374 005	229784	. Cuscinetto a rullini conici	. Tapered roller bearing	1
2	30	0635 372 007	106652	. Cuscinetto a rullini conici	. Tapered roller bearing	1
2	33	0635 370 017	464199	. Cuscinetto a rullini conici	. Tapered roller bearing	1
2	34	0635 373 010	480757	. Cuscinetto a rullini conici	. Tapered roller bearing	1
2	26	3313 302 042	439630	. Spessore 0,1 mm	. Shim 0.1 mm	2
2	26	3313 302 043	439631	. Spessore 0,15 mm	. Shim 0.15 mm	2
2	26	3313 302 044	439632	. Spessore 0,2 mm	. Shim 0.2 mm	2
2	26	3313 302 045	439633	. Spessore 0,5 mm	. Shim 0.5 mm	2
2	26	3313 302 046	439634	. Spessore 1,0 mm	. Shim 1.0 mm	2
2	31	3312 304 022	439393	. Spessore 0,1 mm	. Shim 0.1 mm	2
2	31	3312 304 023	439394	. Spessore 0,15 mm	. Shim 0.15 mm	2
2	31	3312 304 024	439395	. Spessore 0,3 mm	. Shim 0.3 mm	2
2	31	3312 304 025	439396	. Spessore 0,5 mm	. Shim 0.5 mm	2
2	32	3313 304 031	477560	. Spessore 0,1 mm	. Shim 0.1 mm	2
2	32	3313 304 030	477558	. Spessore 0,15 mm	. Shim 0.15 mm	2
2	32	3313 304 029	477557	. Spessore 0,2 mm	. Shim 0.2 mm	2
2	32	3313 304 028	447551	. Spessore 0,5 mm	. Shim 0.5 mm	2
2	37	0630 000 193		. Spessore 40x50x0,10	. Shim 40x50x0.10	1
2	37	0630 000 298		. Spessore 40x50x0,15	. Shim 40x50x0.15	1
2	37	0630 000 274		. Spessore 40x50x0,20	. Shim 40x50x0.20	1